



RESIDENTIAL PRODUCT PLANNING GUIDE

INTRODUCTION

Delaware Elevator, Inc is a family owned full service elevator company, that was established in 1946 with roots dating back to the early 1930's. Our corporate office is located in Salisbury, Maryland with other branch offices and we have representatives in MD, DE, VA, DC, PA, NC, SC, NJ, and throughout FL. Our wide spread locations make it convenient to reach both our national and international clients.

Our continued commitment to providing the best quality of products and services has made us one of the largest independent elevator companies in the nation. Today, Delaware Elevator proudly provides state of the art products for new construction, modernization, residential, handicap access and marine elevators. All of which are supported by our in house manufacturing and unparalleled maintenance.

The goal of Delaware Elevator is to provide responsive service tailored to meet the individual needs of our valued clients and partners. We can confidently affirm that we are large enough to solve any challenge and small enough to provide personal care. We attribute over 75 years of success to our highly skilled employees whom promote safety and quality; which provides the utmost value to our customers. We welcome the opportunity to work with you on all of your vertical transportation needs.

Delaware Elevator's Mission is to achieve our full potential in the vertical transportation industry. We will achieve this through continuous improvements in our products, training, management, and customer service. We are committed to being responsive to the needs of our customers and employees, making their safety and welfare our first priority.

info@delawareelevator.com

TABLE OF CONTENTS

ARCHITECTURAL DRAWINGS

950 LBS:

In Line Opening:

IL-950	13
IR-950	14
XL-950	15
XR-950	16

Front & Rear Opening:

FRL-950	17
FRR-950	18

Adjacent Opening:

AL-950	19
AR-950	20

950 LBS MAX:

In Line Opening:

IL-950 MAX	21
IR-950 MAX	22
XL-950 MAX	23
XR-950 MAX	24

Front & Rear Opening:

FRL-950 MAX	25
FRR-950 MAX	26

Adjacent Opening:

AL-950 MAX	27
AR-950 MAX	28

EQUIPMENT OVERVIEW	1 - 2
--------------------	-------

WORK BY OTHERS	3 - 4
----------------	-------

HOISTWAY REQUIREMENTS	5 - 7
-----------------------	-------

MACHINE ROOM PLAN	8
-------------------	---

SPECIFICATIONS	9 - 12
----------------	--------

ARCHITECTURAL DRAWINGS	13 - 28
------------------------	---------

- 950 LBS ELEVATORS	13 - 20
---------------------	---------

- 950 MAX ELEVATORS	21 - 28
---------------------	---------

NOTES	29
-------	----



EQUIPMENT OVERVIEW

EQUIPMENT

- 1:2 Roped hydraulic drive
- (2) 3/8" diameter hoist cables
- 1-Stage hydraulic piston & cylinder w/self-adjusting seal
- Heavy duty cantilevered designed car sling w/roller guide shoes
- 8 lb/ft steel tee guide rail system
- 220 volt single phase power supply
- Vibration free submersible pump/motor assembly (3 or 5 HP motor)
- 2-Speed control valve and constant down speed regulation

SAFETY DEVICES

- Type "A" instantaneous broken rope car safety
- Pipe rupture valve
- Upper and lower terminal limit switches
- Top final limit switch
- Slack cable switch
- Emergency car lighting in cab
- Emergency stop switch in cab
- Emergency push button alarm in cab
- Automatic car re-leveling device
- Battery lowering device
- Emergency manual lowering valve
- Emergency telephone in cab
- Solid panel cab doors with approved safety switch
- Approved electro mechanical hoistway door interlocks
- Rubber impact bumper below elevator car
- UL and/or CSA certified electrical and hydraulic devices
- Manufactured in accordance with ASME A17.1 safety code

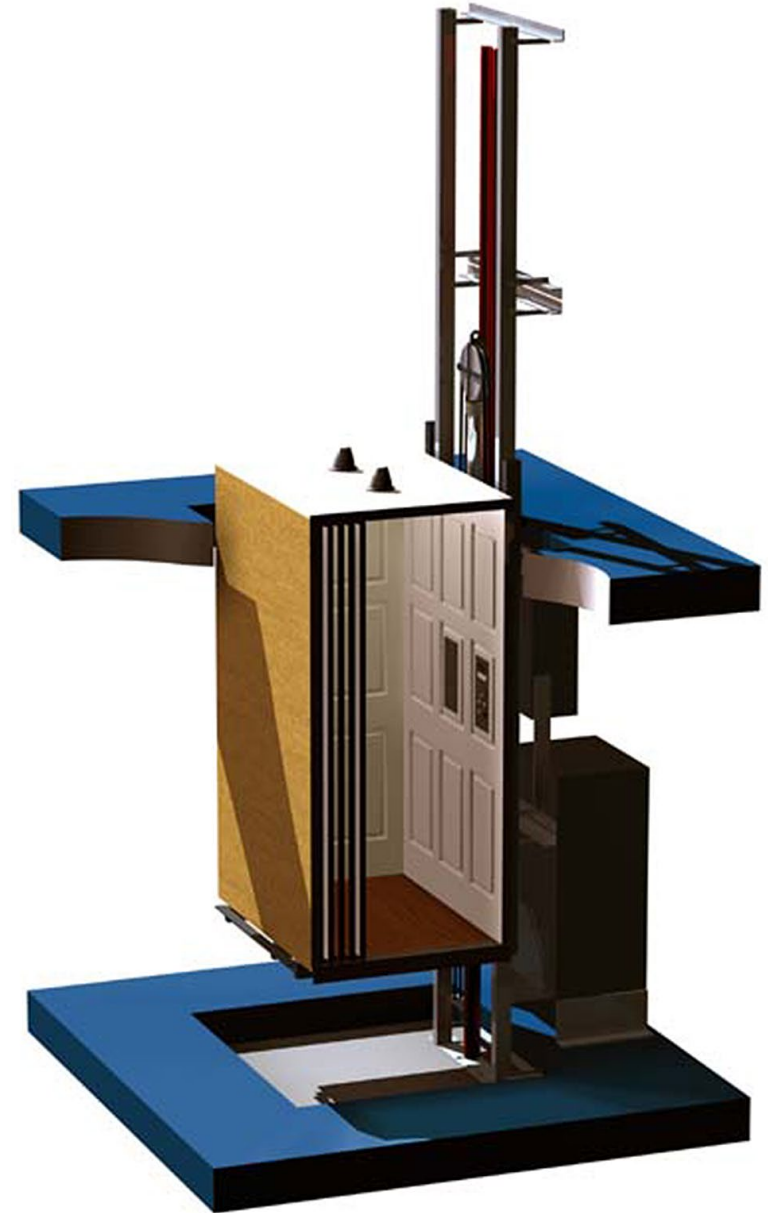

CONTROLS/PUSH BUTTON FIXTURES

- Automatic pushbutton control
- Microprocessor based control system w/battery back up
- Light-up push buttons in car and hall
- Digital floor position indicator in car
- Automatic in car light
- Automatic indicator light time-out feature
- Automatic "Home Park" feature to designated floor
- "Car Here" indicators in hall
- Low oil protection timer circuit

CAB FINISHES & ACCESSORIES

- Cabs available in a wide variety of plastic laminate choices and other options
- Solid panel accordion cab door available in a wide variety of vinyl laminate choices. Lexan & Aluminum also available.
- 36" x 48" x 80" high clear interior cab size with a variety of cab opening configurations
- Brushed stainless steel cab control panel. Other options available.
- Brushed stainless steel handrail on one side wall. Other options available.

CHARACTERISTICS

- Up to 950 lb capacity
- 40 FPM nominal car speed
- Up to 6 stops with 50 feet of floor to floor travel
- Minimum pit depth of 10 inches required (12" recommended)
- Minimum overhead clearance of 8'-0" required (9'-6" recommended)
- Up to 15 square feet interiors cab sizes available (12 ft standard)

WORK DONE BY OTHERS

Prior to job site arrival for installation of elevator, DEI requires the following work by others to be completed.

ELEVATOR HOISTWAY: Provide an enclosed finished LEGAL hoistway with INSIDE, CLEAN, CLEAR, SQUARE, AND PLUMB (including pit) dimensions recommended to be a minimum of 53 inches wide by 57 inches deep (53" X 57") (THIS IS AFTER DRYWALL) including blocking, which will provide an interior cab dimension of approximately 12 square feet. Additional hoistway Plans are available by contacting your local DEI Sales Rep. DEI will build to your specifications if smaller or larger than the above, but only to the smallest dimension inside the clean, clear, square and plumb (including pit) finished drywall hoistway.

Barricades and/or any/all other legal methods required by any jurisdiction to prevent access into shaft shall be required outside each floor landing for the protection of workmen and all other subcontractors and/or occupants until the elevator is installed completely and turned over to the home owner. These devices shall be the sole responsibility of GC. GC TO PROVIDE SOLID CORE HOISTWAY/ LANDING DOORS WITH HINGES LOCATED ON RAIL SIDE.

THRESHOLD: Contractor shall provide a threshold from each floor to 1" of the elevator platform AFTER the elevator has been installed. Doors shall NOT be centered but installed per DEI specs to allow proper rail side return measurement. Rail Side return measurement of at least 12 inches is required. Hoistway side of landing door frames shall NOT have casing or door trim that exceed 1/4" thickness.

PIT: A MINIMUM PIT OF 10 INCHES IS REQUIRED built to withstand 3,900lb maximum load. Minimum 96" overhead clearance is required for 6'-8" cabs (108" for 8'-0" cabs). In any area in a flood zone or any water problems, a monolith type masonry pour is required for pit and its walls to prevent leaks.

TRAVEL DISTANCE: ANY TRAVEL DISTANCES over 28' 0" requires a special piston (2 piece jack) which requires installation during framing stage due to piston length. Contractor to allow DEI four (4) weeks notice to order, deliver and install "Hydraulic Jack" prior to Sheetrock.

WORK DONE BY OTHERS

WOOD FRAME HOME BLOCKING REQUIREMENTS: Four (2 sets of 2 ea.) – 2" X 12" yellow pine studs running vertically the entire length of the hoistway 12 3/4" on center on either side of rail wall centerline of rail wall must be minimum of 28" off inside front wall), 2" X 12" to be face nailed, glued to reduce or prevent creaking, and edged with 2" X 4" for structural integrity. The yellow pine boards shall all be fastened to the wall supports with 3/8" by 2-1/2" lag bolts to support elevator rail system. To insure adequate support in wall for guide rail fastening the blocking should not exceed 10 vertical feet without intermediate horizontal support and shall meet all pertinent building codes. Proper metal tie-ins are recommended for a stronger connection to the framing-such as Simpson Connectors.

CONCRETE BLOCK HOME OR HOISTWAY: All dimensions shall remain the same for INSIDE, CLEAN, CLEAR, SQUARE, AND PLUMB hoistway. Rail sidewall blocks shall filled solid with concrete the entire length of hoistway. One (1) 4' Knockout shall be provided between hoistway and machine room. All patching, fire caulking, painting/grouting required after installation is the responsibility of GC. Through bolts must be permitted or use of masonry inserts must be installed - available at DE, poured block alone is not adequate.

MACHINE ROOM: The contractor shall provide an elevator machine room. UNLESS OTHERWISE SPECIFIED, MACHINE ROOM IS ASSUMED TO BE A LOWEST LEVEL ADJACENT TO ELEVATOR. This area shall be a minimum size of 4' X 4' and to meet all electrical codes. Contractor/Owner is responsible for notifying DEI is Machine Room is located within in a Flood Zone and contractor is responsible for building platform or room above Flood Zone per DEI specifications. If machinery is located in attic, a deck must be built to support loads imposed by unit (Contact DEI for Details) height and accessibility for service and installation should be provided minimum height of 60 inches including catwalk to deck area, scuttle hole and attic ladder. Attic not recommend for hydraulic installations. If machine room is remote (not rail side adjacent) contractor is responsible for coordinating the timely installation of 3/4' seamless schedule 80 black pipe. DEI will install, but we must have ample time and access.

ELECTRICAL: Standard 220 Volt 30 Amp dedicated service 10-3 wire with ground and standard 110, 15 Amp single pole circuit breaker (both with eight feet of length from inside machine room wall penetration) and telephone line shall all be located in machine room. PLEASE BE ADVISED THAT POWER ON THE 220V LINE MUST BE A 10-3 WIRE WITH A GROUND AND INSURE THERE IS A DEDICATED NEUTRAL TO THE UNIT. IN ADDITION, ELECTRICAL CONTRACTOR TO SUPPLY AND INSTALL 240V-30 AMP DISCONNECT WITH INTERLOCK KIT PLUS 2 EACH 250V RK5 FUSE, AND SINGLE POLE 110V-15A DISCONNECT. Explanation: The 220V feed should have a black, red, white and ground wire coming to the machine room. All electrical contractors will have full knowledge of this requirement. Simply insure they are aware of the requirement. Black and red are powered with 110V each totaling 220V. White is neutral to feed low voltage transformer with 110V. Ground to ground standard. (See DEI Electrical requirements sheet.)

General contractor and/or Owner shall Indemnify and hold DEI harmless for all claims subject to this "Work Done By Others". Cancellation fees apply. See DEI representative for details. ANY WORK DONE BY OTHERS HEREIN NOT FULLY COMPLETE PRIOR TO TIME OF INSTALLATION SHALL RESULT IN A REMOBILIZATION FEE OF \$750. NOTE: INFORMATION SUBJECT TO CHANGE WITHOUT NOTICE.

HOISTWAY REQUIREMENTS

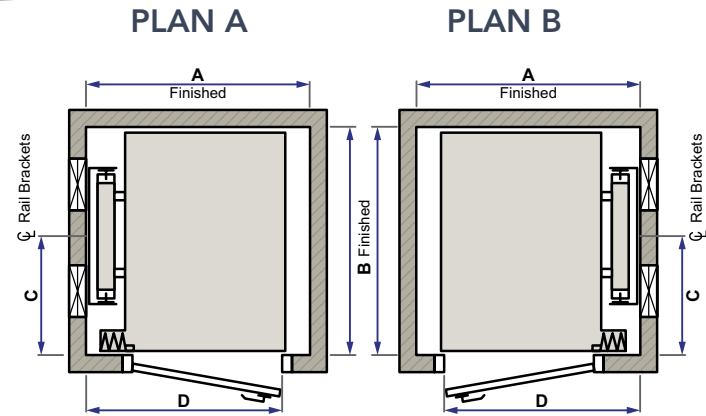

Capacity	A	B	C	D
950 lbs.	4'-6"	4'-8"	2'-4½"	3'-11"

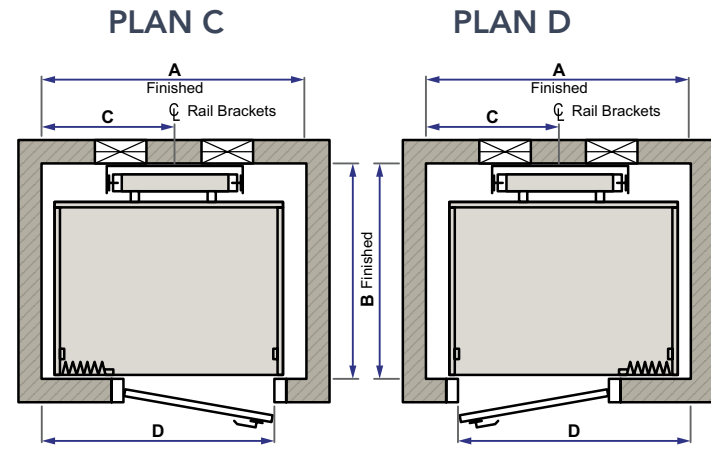

Capacity	A	B	C	D
950 lbs.	4'-10"	4'-6"	2'-3"	4'-3"

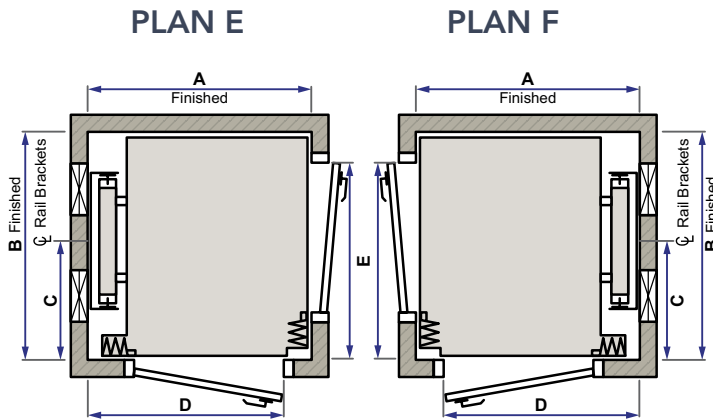

Capacity	A	B	C	D	E
950 lbs.	4'-6"	4'-11"	2'-4½"	4'-0"	4'-4"

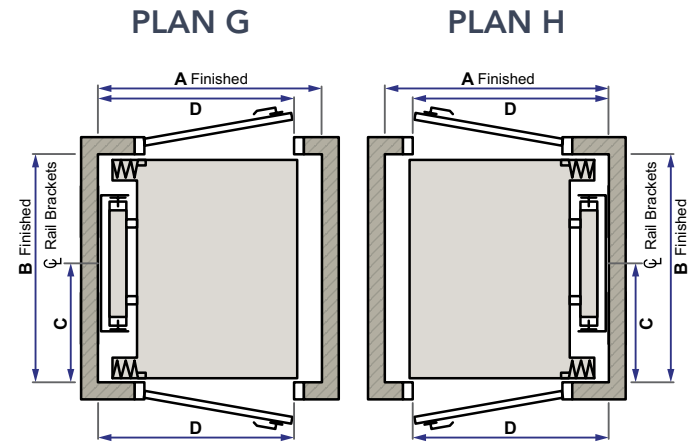

Capacity	A	B	C	D
950 lbs.	4'-6"	4'-10"	2'-5"	3'-11"

HOISTWAY RECOMMENDATION

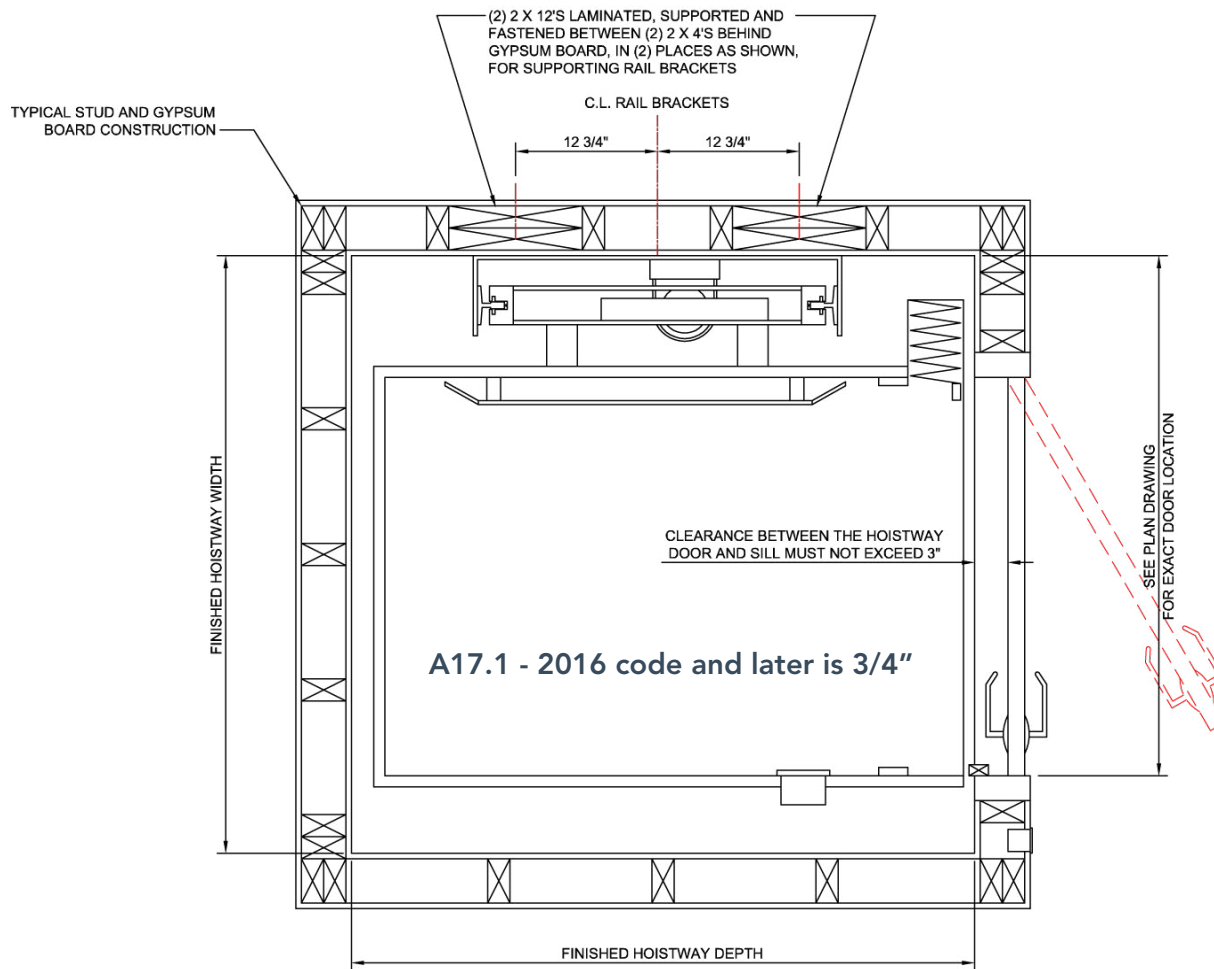

Notes:

- Provide a legally constructed and enclosed machine room, adequately lighted, and conditioned to maintain temperature between 65° to 95° Fahrenheit, relative humidity is not to exceed 95% non-condensing.
- Machine room must be of adequate size to provide clearances around and between equipment as required by code.
- Provide a fused disconnect switch for each elevator in the machine room, located in a position based on local code and within sight of elevator equipment, and arranged to be locked in the off position. Not lockable in the ON position.
- Provide 110 VAC service for elevator light and accessories connected to the car light service terminal on the elevator controller. A single disconnecting means for the car light and accessories shall be located in the machine room and arranged to be locked in the open position.
- Provide light, switch and 110 VAC GFI outlet in the machine room, with switch located adjacent to the machine room door.
- Only elevator related equipment is allowed in machine room.

HOISTWAY RECOMMENDATION

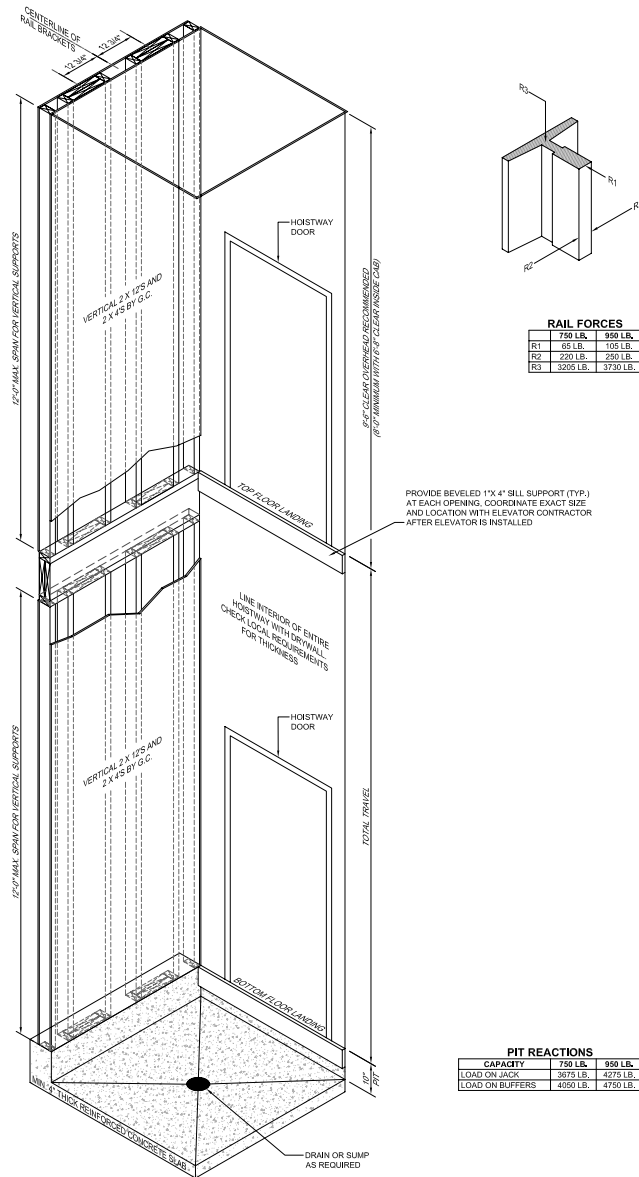

Minimum Requirements for Hydraulic Elevators

1. 52" x 56" clear inside hoistway dimensions when using an accordion style solid gate.
2. 10" minimum pit built to withstand a 3,900 lb load.
3. 96" clear hoistway overheard for 6'-8" cab.
4. 11" minimum return on rail side wall. If this cannot be obtained, contact office for approval.
5. If masonry construction, rail wall needs to have inserts sold by Delaware Elevator.
6. Rail side blocking for wood frame hoistways must be two 2 x 12's sandwiched together, running vertically the entire length of the hoistway 12 3/4" on the center of either side of the rail bracket centerline. (Please see rail wall structural drawing.) Build same as a header.
7. Any travel distances over 28'-0" will incur a special order charge for larger piston travel. (Add approximately one month to the standard delivery time.)
8. Machine room to be located adjacent to rail wall on first floor.
9. Remote machine rooms to be approved by the office and are an upcharge.
10. Machine room to be 48" x 48" or large enough to accommodate pump controller without restricting access, and as per code. 7' Minimum headroom recommended.

MINIMUM MACHINE ROOM

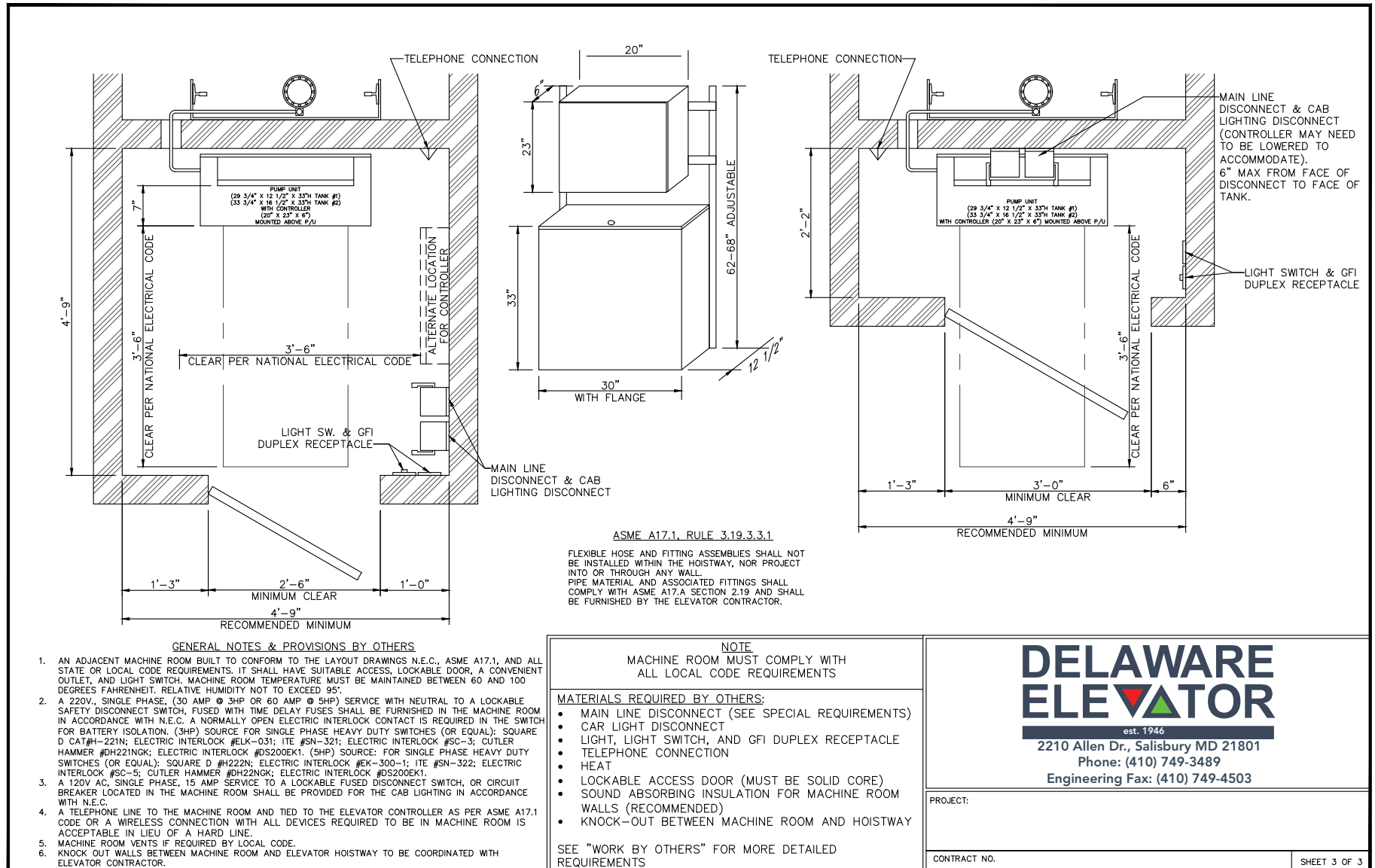

SPECIFICATIONS

Part 1: General

1.1 Description of Work

To furnish all labor and materials required to cover a complete installation of (one) roped hydraulic residential elevator. The elevator is to be installed in a first class workmanlike manner in accordance with the specification and drawings provided.

1.2 Work By Others

The following preparatory work to accommodate the elevator installation is to be done by others and is part of work of other sections.

A. Hoistway

1. A finished plumb hoistway of proper size and construction conforming to ASME A17.1 all applicable building codes, and the elevator layout drawings.

2. Adequate supports shall be provided for fastening rail brackets as indicated on the layout drawings. Supports must withstand rail forces indicated.

3. A poured pit conforming to all applicable codes, ASME A17.1, and to the dimensions indicated on the layout drawings must be provided. The pit must be designed for the impact load indicated and must be guaranteed dry and level from wall to wall.

4. Knock-out in walls between the machine room and elevator hoistway for routing hydraulic and electrical lines and for hall buttons shall be coordinated with the elevator contractor.

5. All wall patching, painting, and grouting by others.

6. Hoistway doors, frames, entrances, sills, and associated framing to be provided and installed by purchaser or general contractor.

B. Machine Room

1. An adjacent machine room built to conform to the layout drawings, NFPA

70, ASME A17.1, and all applicable building code requirements. It shall have suitable access, a lockable door, a convenience outlet, and light switch. Machine room temperature must be maintained between 60 and 100 degrees. Relative humidity not to exceed 95%.

2. A telephone line to the machine room and tied into the elevator controller as per ANSI/AMSE A17.1 code.

3. Machine room vents as required by local Code.

C. Electrical Requirements

1. A 220 VAC, single phase service, with neutral, to a lockable safety disconnect switch, fused with time delay fuses shall be furnished in the machine room in accordance with NFPA 70. A normally open electric interlock contact is required in the switch for battery isolation.

2. A 120 VAC, single phase, 15 AMP service to a lockable disconnect switch, or circuit breaker, located in the machine room shall be provided for the cab lighting in accordance with NFPA 70.

1.3 Quality Assurance

The elevator shall be designed, manufactured, installed, and inspected in accordance with ANSI/ASME A17.1 standards and all applicable regulations of federal, state, and local agencies having jurisdiction.

A. References

1. American National Standards Institute (ANSI)

2. American Society of Mechanical Engineers (AMSE)

3. National Electric Code (NFPA 70)

4. CSA B44.1/ASME A17.1, elevator and escalator electrical equipment requirements.

B. Qualifications

The installation shall be performed by a company with no less than (5) years of successful experience in the assembly and erection of similar type elevators and who has adequate product liability insurance.

C. Regulatory Requirements

The elevator installer shall verify requirements of the local authority having jurisdiction and shall obtain and pay for necessary municipal and state permits and inspections as required, and make tests as called for by the regulations of such authorities.

Part 2: Submittal

Part 2: Submittal

2.1 Product Data

Submit manufacturer literature including product data, cab design, color charts, signal fixtures and specification.

2.2 Layout Drawings

Layout drawings shall be submitted showing the general arrangement of the elevator equipment including dimensions, clearances, location of machine equipment, and all loads and reactions imposed on pit and building structure.

Part 3: Products

3.1 Manufacturer

The roped hydraulic residential elevator shall be manufactured by DEM Co., 27685 Rockawalkin Ridge Road, Salisbury, MD 21801. U.S. Toll Free 1-800-787-0436 or Fax 410-341-7505

3.2 Characteristics
Type: Roped 2:1 Hydraulic

Capacity: 950 lbs. Car Speed: 40 FPM

Operation: SAPB/Single Button Collective

Travel:

Number of Stops: Number of Openings:

Inside Car Dimensions: 36" x 48" x 80" high Power Supply: 220 Volt, single phase, 60 Hz. Cab Design:

Push Button Faceplate and Handrail Finish:

SPECIFICATIONS

3.3. Equipment

A. Operations

Operation of the elevator shall be single automatic push button or single button collective (field programmable); momentary pressure on any button will call or send the elevator to the corresponding landing providing all doors are closed.

1. Battery Lowering: In the event of a

Power failure, the elevator shall automatically descend to the next landing, and can proceed to the bottom landing while monitoring all safety circuits. If the elevator is equipped with a power car door(s) option, the car door(s) shall open and close automatically. Batteries are to have an automatic charging system.

2. Emergency car lighting: In the event of a power failure, the car lights shall automatically transfer to battery power.

3. Home park Feature: The elevator shall automatically return to a field of programmable designated landing after one minute without use. (per preference)

4. Automatic two-way leveling: the Leveling device shall automatically stop and maintain the car within ½ inch of the landing regardless of change in load

5. Low oil control: A low oil control feature shall be provided designed to automatically cause an up travel car to descend to the lowest terminal if the elevator should fail to reach a landing in a predetermined time or if the system does not have a sufficient reservoir of oil.

B. Control Systems

A microprocessor based control system certified and labels to the requirements of CAN/CSA-B44.1/AMSE A17.1 shall be provided. It shall include a motor starter with a potential relay, motor overload device, an uninterrupted power supply with battery charging circuit, and external relay redundancy circuits to prevent dangerous conditions as a result of a single contact failure. All circuits shall be fuse protected.

All to be enclosed in a single NEMA 1 cabinet.

C. Hydraulic Power Unit

The hydraulic power unit shall include a submersible motor, rotary screw type pump, two-speed control valve and oil reservoir with an oil level gauge. The control valve shall include safety check valve, up and down acceleration, deceleration, leveling and soft stop adjustments, pressure relief valve, manual lowering valve, constant down speed regulation, pressure gauge with shutoff, negative pressure switch and manual shutoff valve all mounted and enclosed in a compact unit assembly with a key lockable cover.

D. Plunger and Cylinder

The cylinder shall be constructed of steel pipe with a steel bulk plate welded to the lower end and a cylinder head welded to the upper end which houses the self adjusting packing bearings wiper, are bleeder, and leach line hose. The plunger shall be manufactured from accurately ground and polished tubing fitted with a steel stop ring welded to the bottom to prevent the plunger from leaving the cylinder in the up direction.

E. Pipe Rupture Valve

An automatic shut off valve at the cylinder inlet shall be provided to stop and hold the elevator in the event of a main oil line failure or if the elevator should over speed in the down direction.

F. Car Frame and Platform

The car frame shall be fabricated from structural and formed steel members, welded and bolted construction, of the cantilevered design.

G. Car Suspension

The elevator car frame shall be suspended by (2) 3/8" diameter, 6 x19, traction steel cables. The cables shall dead end to the pit steel on one end, pass a "U" groove sheave, and attach to the car safety device with approved type wedge sockets.

H. Guide Rails

The car guide rails shall consist of (2) machined steel "tee" sections, no less than 8 lb. per foot, securely fastened to the hoistway structure with steel brackets. All rail end sections shall be tongue & grove type joined with steel splice plates.

I. Car Operating Panel

Car operating panel shall consist of metal lens call push button with red LED halo lighting for each landing, an alarm button, emergency stop button, light switch, and a digital car position indicator with car direction arrows all mounted onto a brushed stainless steel faceplate (brass optional) Digital C.P.I. shall be field programmable. Phone build into panel.

J. Landing Controls

Landing controls stations shall consist of a metal lens call button and a "car here" indicator with red LED halo lighting mounted onto a brushed stainless steel faceplate (brass optional).

K. Hoistway Doors

The general contractor or owner is to furnish (elevator contractor may opt to furnish) and install hoistway doors, frames, hinges, and passage sets at each landing. The type and installation of the doors and frames must

comply with ASME A17.1, all state and local codes and as per manufacturer's layout drawings.

L. Car Door(s)

The car door(s) shall be solid panel construction accordion type folding door(s) that prevent a person's hands or feet from extending through openings. Finish shall be vinyl laminate chosen from the manufacturer's standards color selection (hardwood, visifold, and alumifold optional). Car door shall be equipped with a positive contact switch to prevent elevator operation with the car door(s) open (power car door(s) optional).

M. Car Enclosure

The cab walls shall be constructed of ¾" minimum substrates faced with plastic laminate or wood veneers with wood trim accents as selected from the manufacturer's standard designs. A brushed stainless steel handrail (brass optional) shall be located on one wall. A telephone shall be furnished in the elevator cab for emergency communication. Cab ceiling shall be a minimum of ¾" thick substrate with at least a (2) bulb light fixture as selected from the manufacturer's standard ceiling designs. Finished flooring covering is to be furnished by others.

N. Electrical Wiring

All wiring and electrical materials shall conform to NFPA 70 and with all applicable codes. Insulated wiring shall have flame retardant and moisture proof outer covering and shall be run in conduit or electrical wire ways as required. Traveling cables shall be flexible and suitable suspended to relieve strain.

Part 4: EXECUTION

4.1 Examination

Elevator installer shall verify dimensions of hoistway, pit, machine room, and inspect condition of supports and structure prior to installation.

4.2 Installation

The elevator shall be installed in accordance with the manufacturer's instructions and shall conform to ASME A17.1 and all state and local code requirements.

4.3 Operating Instructions

Upon completion of the installation, the owner shall be instructed on the elevator's operation, safety precautions, and maintenance requirements. The owner will be supplied with an owner's manual to retain for reference.

4.4 Maintenance

The elevator shall be maintained in accordance with the manufacturer's recommendations and all applicable codes

4.5 Warranty

The elevator shall have a (1) year limited parts warranty.

IN LINE OPENING IL-950

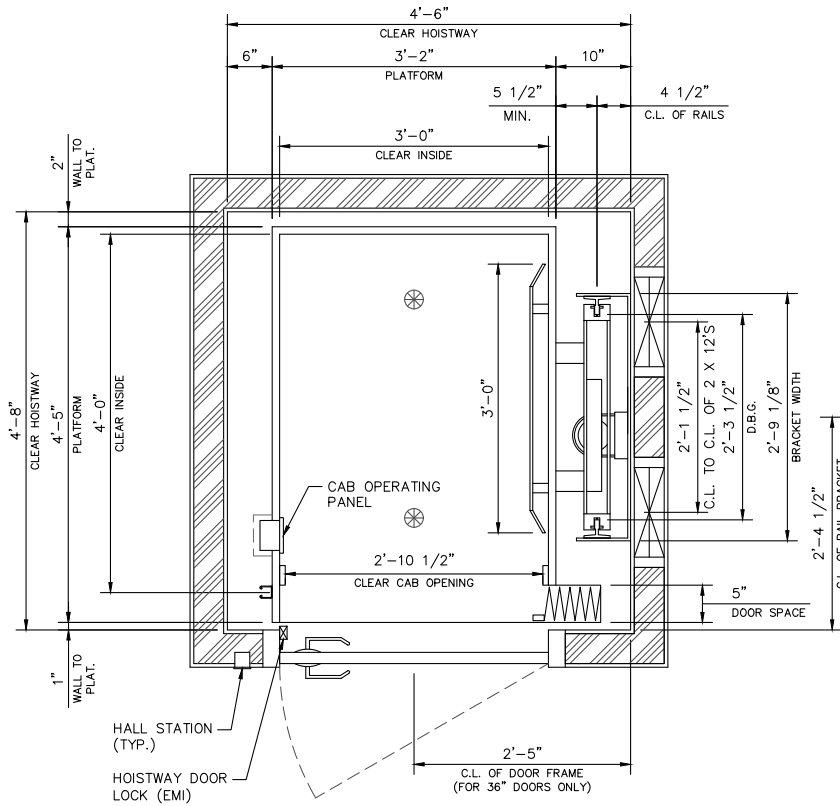

TECHNICAL DATA

		950 LB. CAP.	ALL REACTIONS DOUBLED FOR IMPACT HORIZONTAL GUIDE RAIL REACTIONS
	R1	105 LB	
	R2	220 LB	
	R3	3730 LB	

DEM 950

NORMAL	JACK LOAD 4275 LB	BUFFER LOAD 4750 LB	CODE YEAR ASME A17.1 2013
--------	----------------------	------------------------	------------------------------

GENERAL INFORMATION		
CAPACITY: 950	SPEED: 40 FPM	STOPS:
OPERATION: SINGLE AUTO	CONTROL: AC MOTOR	OPENINGS:

ELECTRICAL INFORMATION		
POWER: 220 VOLTS AC	1 PHASE	60 HERTZ
HORSE POWER: 3	FLA: 14	RPM: 1725
LIGHT SUPPLY: 110	EMERGENCY BATTERY LIGHTING	

JACK INFORMATION		
PLUNGER DIAMETER:	PLUNGER WALL THICKNESS: .240"	
CYLINDER DIAMETER: 4.5"	CYLINDER WALL THICKNESS: .237"	
TRAVEL:	CLEAR OVERHEAD:	PIT DEPTH:
TOTAL HOISTWAY:	ROPES: (2) 3/8"	PILLAR HEIGHT:
COLLAPSED LENGTH:	STROKE:	JACK WEIGHT:
WORKING PSI:	RELIEF PSI:	GPM
UP OVERTRAVEL:	DOWN OVERTRAVEL:	

HOISTWAY INFORMATION	
LOCATION OF PILLAR BRKT:	PISTON EXT.:
NUMBER OF BRACKETS:	BUFFER TYPE: RUBBER PAD
BUFFER TYPE: RUBBER PAD	BUFFER STROKE: N/A
OIL LINE: 3/4" SCH 80	OIL REQUIRED: 35 GAL.
GATE TYPE: <input type="checkbox"/> POWERED <input checked="" type="checkbox"/> MANUAL <input checked="" type="checkbox"/> ACCORDION <input type="checkbox"/> SCISSOR	
CAB HEIGHT:	DOOR SIZE:
<input type="checkbox"/> SUBFRAME (2" CLEARANCE)	<input type="checkbox"/> NON-SUBFRAME (1" CLEARANCE)



2210 Allen Dr., Salisbury MD 21801
 Phone: (410) 749-3489
 Engineering Fax: (410) 749-4503

PROJECT: **IL - 950**

REV.	DESCRIPTION	APPROVAL
	PRELIMINARY	

CONTRACT NO. _____ SHEET 1 OF 3

IN LINE OPENING IR-950

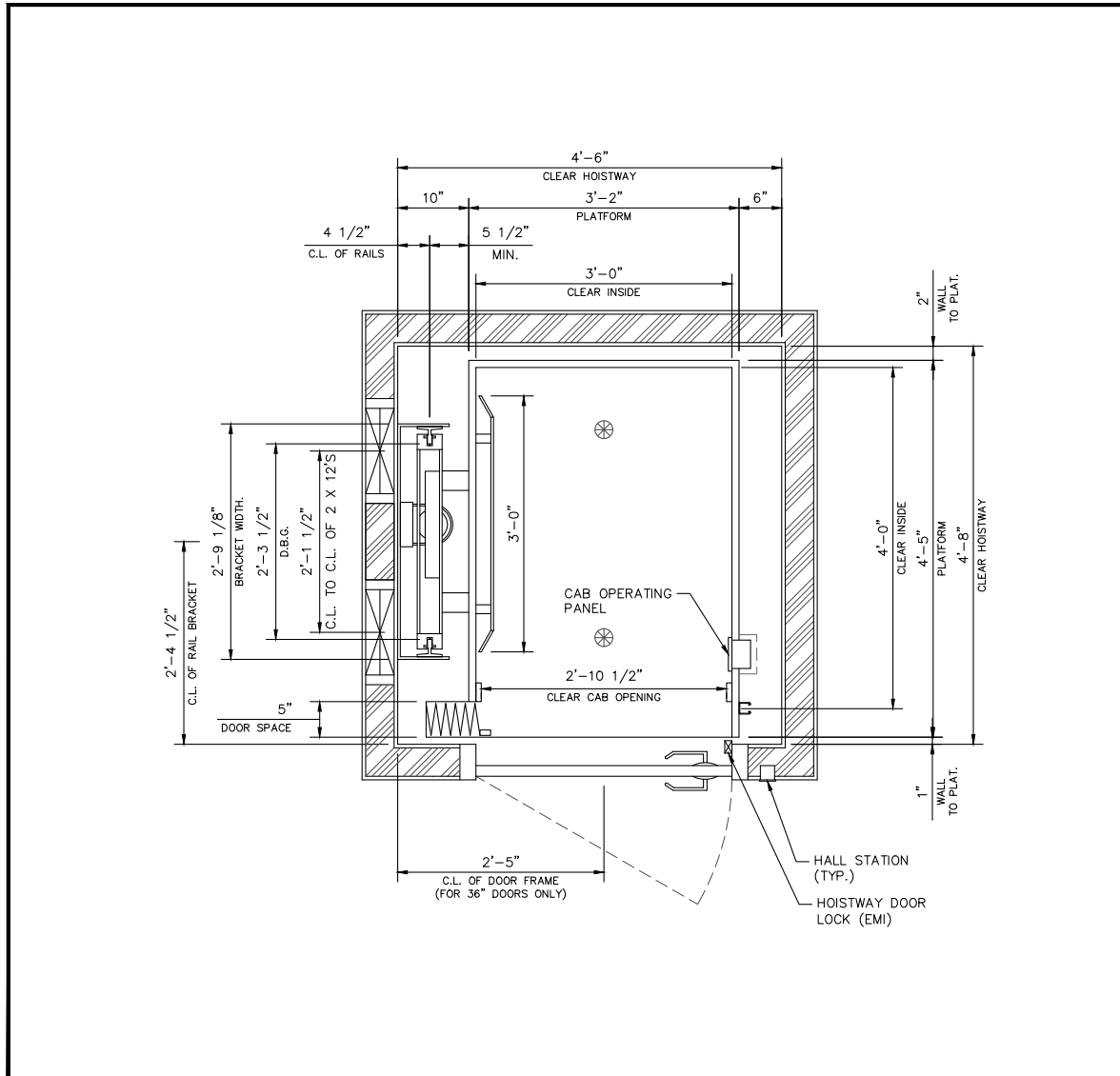

TECHNICAL DATA

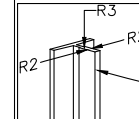

	950 LB. CAP.
R1	105 LB
R2	220 LB
R3	3730 LB

ALL REACTIONS DOUBLED
FOR IMPACT
HORIZONTAL GUIDE RAIL
REACTIONS

DEM 950

NORMAL	JACK LOAD 4275 LB	BUFFER LOAD 4750 LB	CODE YEAR ASME A17.1 2013
--------	----------------------	------------------------	------------------------------

GENERAL INFORMATION		
CAPACITY: 950	SPEED: 40 FPM	STOPS:
OPERATION: SINGLE AUTO	CONTROL: AC MOTOR	OPENINGS:

ELECTRICAL INFORMATION		
POWER: 220 VOLTS AC	1 PHASE	60 HERTZ
HORSE POWER: 3	FLA: 14	RPM: 1725
LIGHT SUPPLY: 110	EMERGENCY BATTERY LIGHTING	

JACK INFORMATION		
PLUNGER DIAMETER:	PLUNGER WALL THICKNESS: .240"	
CYLINDER DIAMETER: 4.5"	CYLINDER WALL THICKNESS: .237"	
TRAVEL:	CLEAR OVERHEAD:	PIT DEPTH:
TOTAL HOISTWAY:	ROPES: (2) 3/8"	PILLAR HEIGHT:
COLLAPSED LENGTH:	STROKE:	JACK WEIGHT:
WORKING PSI:	RELIEF PSI:	GPM:
UP OVERTRAVEL:	DOWN OVERTRAVEL:	

HOISTWAY INFORMATION	
LOCATION OF PILLAR BRKT:	
NUMBER OF BRACKETS:	PISTON EXT.:
BUFFER TYPE: RUBBER PAD	BUFFER STROKE: N/A
OIL LINE: 3/4" SCH 80	OIL REQUIRED: 35 GAL.
GATE TYPE: <input type="checkbox"/> POWERED <input checked="" type="checkbox"/> MANUAL <input checked="" type="checkbox"/> ACCORDION <input type="checkbox"/> SCISSOR	
CAB HEIGHT:	DOOR SIZE:
<input type="checkbox"/> SUBFRAME (2" CLEARANCE)	<input type="checkbox"/> NON-SUBFRAME (1" CLEARANCE)



2210 Allen Dr., Salisbury MD 21801
Phone: (410) 749-3489
Engineering Fax: (410) 749-4503

PROJECT:

IR - 950

REV.	DESCRIPTION	APPROVAL
	PRELIMINARY	

CONTRACT NO.

SHEET 1 OF 3

IN LINE OPENING XL-950

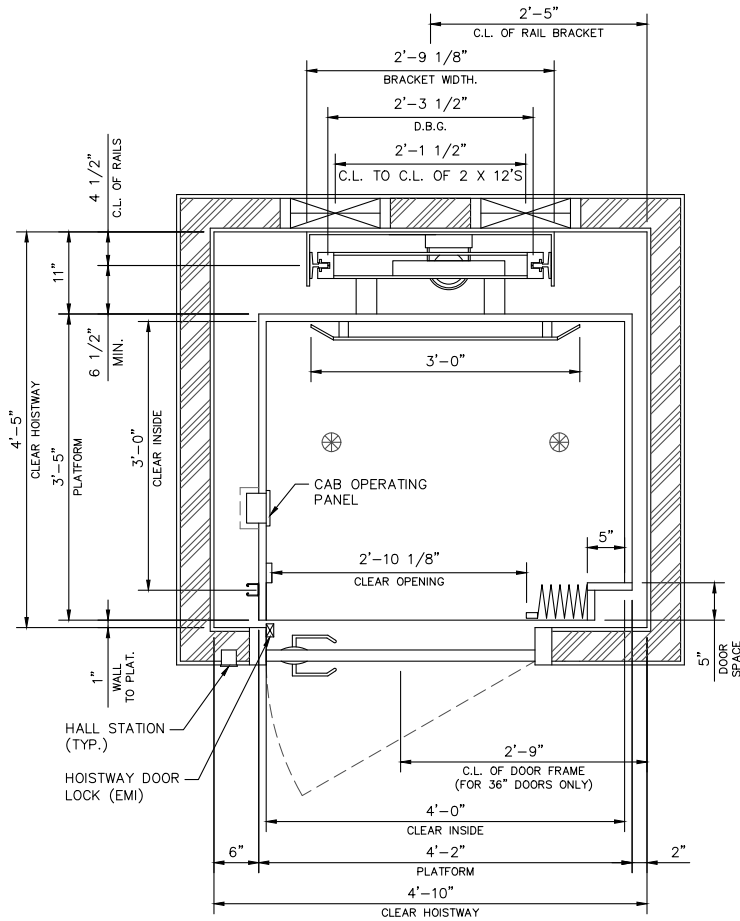

TECHNICAL DATA

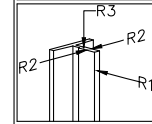

	950 LB. CAP.
R1	105 LB
R2	220 LB
R3	3730 LB

ALL REACTIONS DOUBLED
FOR IMPACT
HORIZONTAL GUIDE RAIL
REACTIONS

DEM 950

NORMAL	JACK LOAD	BUFFER LOAD	CODE YEAR
	4275 LB	4750 LB	ASME A17.1 2013

GENERAL INFORMATION		
CAPACITY: 950	SPEED: 40 FPM	STOPS:
OPERATION: SINGLE AUTO	CONTROL: AC MOTOR	OPENINGS:

ELECTRICAL INFORMATION		
POWER: 220 VOLTS AC	1 PHASE	60 HERTZ
HORSE POWER: 3	FLA: 14	RPM: 1725
LIGHT SUPPLY: 110	EMERGENCY BATTERY LIGHTING	

JACK INFORMATION		
PLUNGER DIAMETER:	PLUNGER WALL THICKNESS: .240"	
CYLINDER DIAMETER: 4.5"	CYLINDER WALL THICKNESS: .237"	
TRAVEL:	CLEAR OVERHEAD:	PIT DEPTH:
TOTAL HOISTWAY:	ROPES: (2) 3/8"	PILLAR HEIGHT:
COLLAPSED LENGTH:	STROKE:	JACK WEIGHT:
WORKING PSI:	RELIEF PSI:	GPM
UP OVERTRAVEL:	DOWN OVERTRAVEL:	

HOISTWAY INFORMATION		
LOCATION OF PILLAR BRKT:	PISTON EXT.:	
NUMBER OF BRACKETS:	BUFFER STROKE: N/A	
BUFFER TYPE: RUBBER PAD	OIL LINE: 3/4" SCH 80	
OIL LINE: 3/4" SCH 80	OIL REQUIRED: 35 GAL.	
GATE TYPE: <input type="checkbox"/> POWERED <input checked="" type="checkbox"/> MANUAL <input checked="" type="checkbox"/> ACCORDION <input type="checkbox"/> SCISSOR	CAB HEIGHT:	
<input type="checkbox"/> SUBFRAME (2" CLEARANCE) <input type="checkbox"/> NON-SUBFRAME (1" CLEARANCE)	DOOR SIZE:	



2210 Allen Dr., Salisbury MD 21801
Phone: (410) 749-3489
Engineering Fax: (410) 749-4503

PROJECT:

XL - 950

REV.	DESCRIPTION	APPROVAL
	PRELIMINARY	

CONTRACT NO.

SHEET 1 OF 3

IN LINE OPENING XR-950

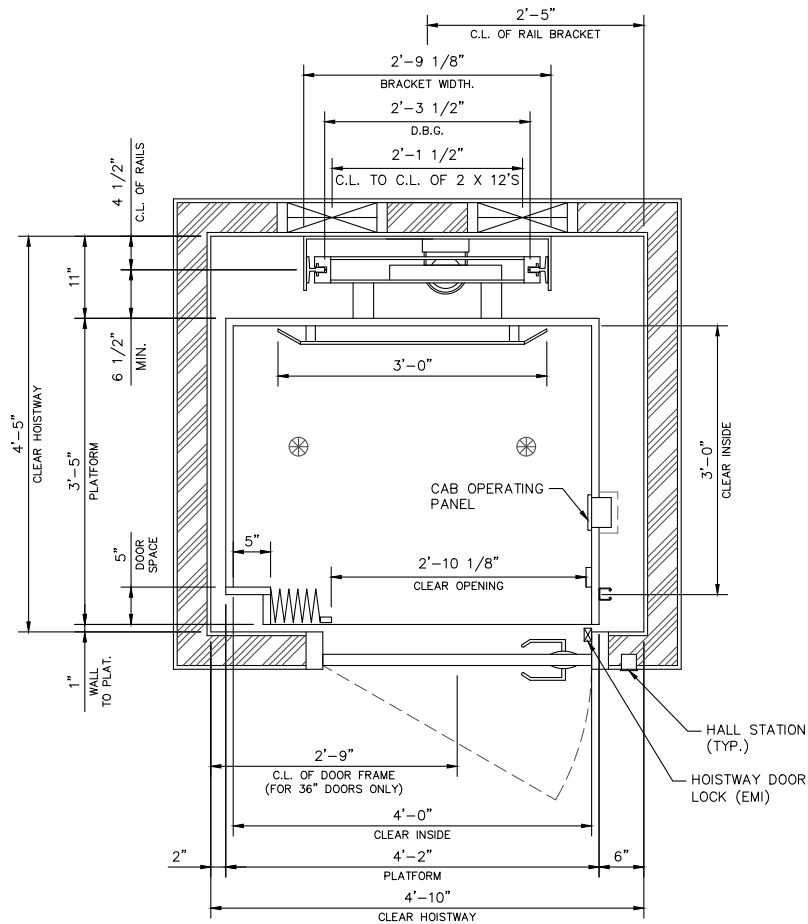

TECHNICAL DATA

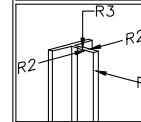

	950 LB. CAP.
R1	105 LB
R2	220 LB
R3	3730 LB

ALL REACTIONS DOUBLED FOR IMPACT HORIZONTAL GUIDE RAIL REACTIONS

DEM 950

	JACK LOAD	BUFFER LOAD	CODE YEAR
NORMAL	4275 LB	4750 LB	ASME A17.1 2013

GENERAL INFORMATION		
CAPACITY: 950	SPEED: 40 FPM	STOPS:
OPERATION: SINGLE AUTO	CONTROL: AC MOTOR	OPENINGS:

ELECTRICAL INFORMATION		
POWER: 220 VOLTS AC	1 PHASE	60 HERTZ
HORSE POWER: 3	FLA: 14	RPM: 1725
LIGHT SUPPLY: 110	EMERGENCY BATTERY LIGHTING	

JACK INFORMATION	
PLUNGER DIAMETER:	PLUNGER WALL THICKNESS: .240"
CYLINDER DIAMETER: 4.5"	CYLINDER WALL THICKNESS: .237"
TRAVEL:	CLEAR OVERHEAD:
TOTAL HOISTWAY:	ROPES: (2) 3/8"
COLLAPSED LENGTH:	STROKE:
WORKING PSI:	RELIEF PSI:
UP OVERTRAVEL:	DOWN OVERTRAVEL:

HOISTWAY INFORMATION	
LOCATION OF PILLAR BRKT:	PISTON EXT.:
NUMBER OF BRACKETS:	BUFFER STROKE: N/A
BUFFER TYPE: RUBBER PAD	OIL REQUIRED: 35 GAL.
OIL LINE: 3/4" SCH 80	GATE TYPE: <input type="checkbox"/> POWERED <input checked="" type="checkbox"/> MANUAL <input checked="" type="checkbox"/> ACCORDION <input type="checkbox"/> SCISSOR
CAB HEIGHT:	DOOR SIZE:
<input type="checkbox"/> SUBFRAME (2" CLEARANCE)	<input type="checkbox"/> NON-SUBFRAME (1" CLEARANCE)



2210 Allen Dr., Salisbury MD 21801
 Phone: (410) 749-3489
 Engineering Fax: (410) 749-4503

PROJECT:

XR - 950

REV.	DESCRIPTION	APPROVAL
	PRELIMINARY	
CONTRACT NO.		SHEET 1 OF 3

FRONT & REAR FRL-950

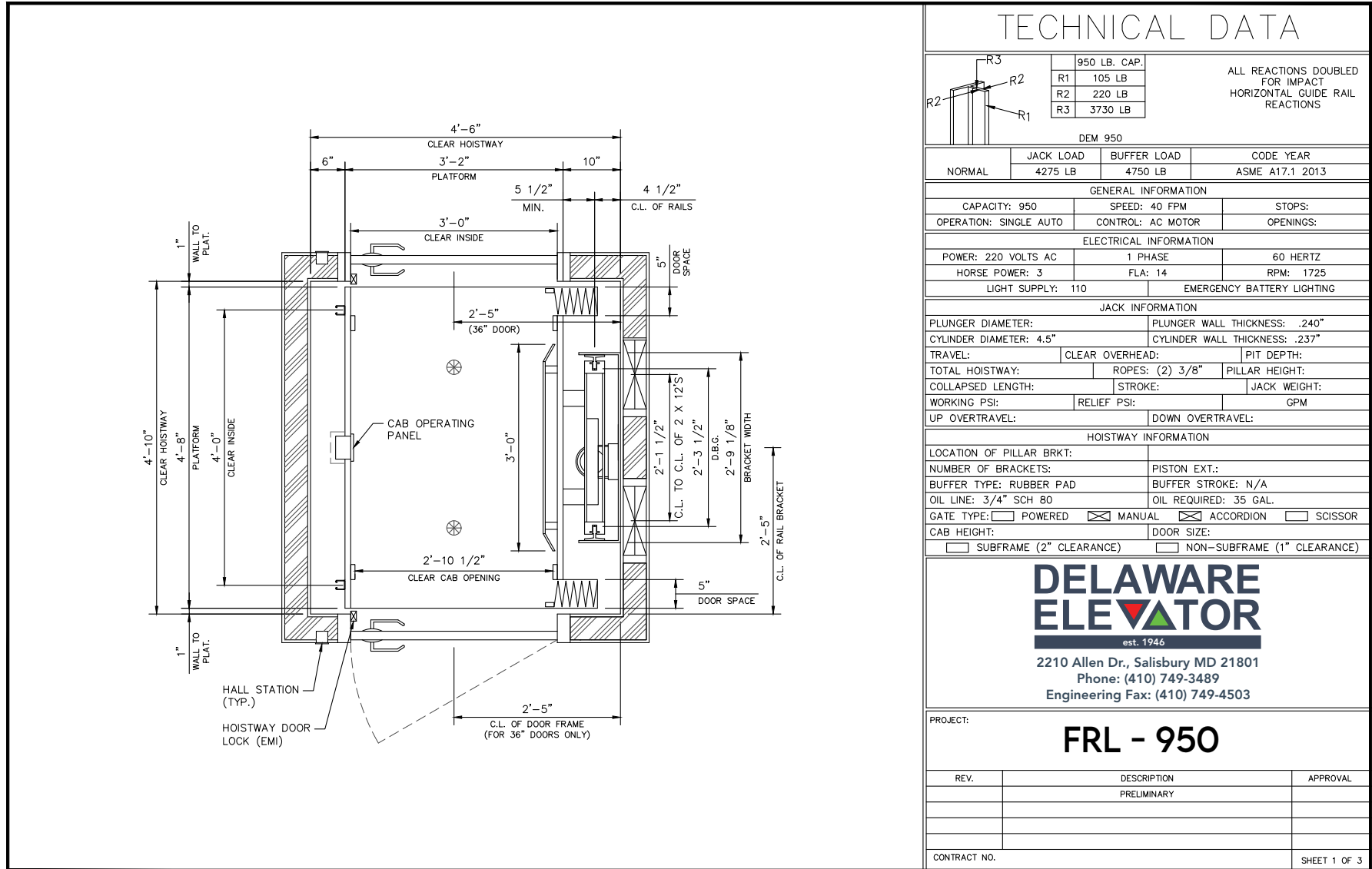

FRONT & REAR FRR-950

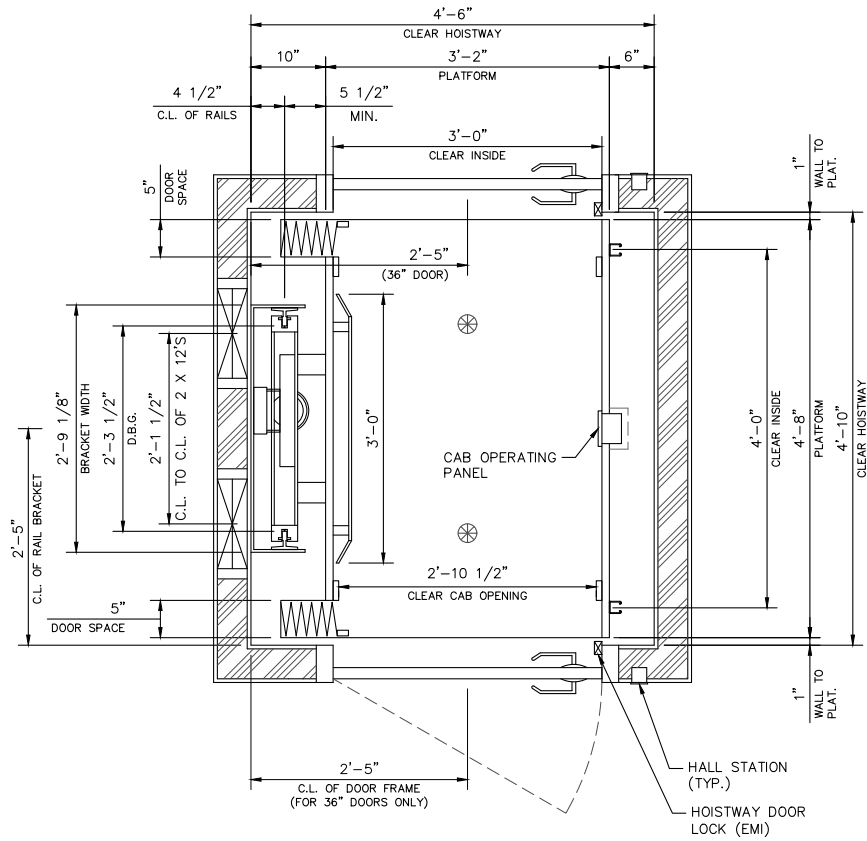

TECHNICAL DATA

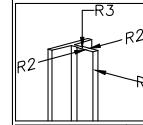

	950 LB. CAP.
R1	105 LB
R2	220 LB
R3	3730 LB

ALL REACTIONS DOUBLED FOR IMPACT HORIZONTAL GUIDE RAIL REACTIONS

DEM 950

NORMAL	JACK LOAD	4275 LB	BUFFER LOAD	4750 LB	CODE YEAR	ASME A17.1 2013
	GENERAL INFORMATION					

CAPACITY: 950	SPEED: 40 FPM	STOPS:
OPERATION: SINGLE AUTO	CONTROL: AC MOTOR	OPENINGS:

ELECTRICAL INFORMATION		
POWER: 220 VOLTS AC	1 PHASE	60 HERTZ
HORSE POWER: 3	FLA: 14	RPM: 1725
LIGHT SUPPLY: 110 EMERGENCY BATTERY LIGHTING		

JACK INFORMATION		
PLUNGER DIAMETER:	PLUNGER WALL THICKNESS: .240"	
CYLINDER DIAMETER: 4.5"	CYLINDER WALL THICKNESS: .237"	
TRAVEL:	CLEAR OVERHEAD:	PIT DEPTH:
TOTAL HOISTWAY:	ROPES: (2) 3/8"	PILLAR HEIGHT:
COLLAPSED LENGTH:	STROKE:	JACK WEIGHT:
WORKING PSI:	RELIEF PSI:	GPM
UP OVERTRAVEL:	DOWN OVERTRAVEL:	

HOISTWAY INFORMATION	
LOCATION OF PILLAR BRKT:	PISTON EXT.:
NUMBER OF BRACKETS:	BUFFER STROKE: N/A
BUFFER TYPE: RUBBER PAD	OIL LINE: 3/4" SCH 80
OIL LINE: 3/4" SCH 80	OIL REQUIRED: 35 GAL.
GATE TYPE: <input type="checkbox"/> POWERED <input checked="" type="checkbox"/> MANUAL <input checked="" type="checkbox"/> ACCORDION <input type="checkbox"/> SCISSOR	CAB HEIGHT:
<input type="checkbox"/> SUBFRAME (2" CLEARANCE) <input type="checkbox"/> NON-SUBFRAME (1" CLEARANCE)	DOOR SIZE:



2210 Allen Dr., Salisbury MD 21801
Phone: (410) 749-3489
Engineering Fax: (410) 749-4503

PROJECT:

FRR - 950

REV.	DESCRIPTION	APPROVAL
	PRELIMINARY	

CONTRACT NO.

SHEET 1 OF 3

ADJACENT OPENING AL-950

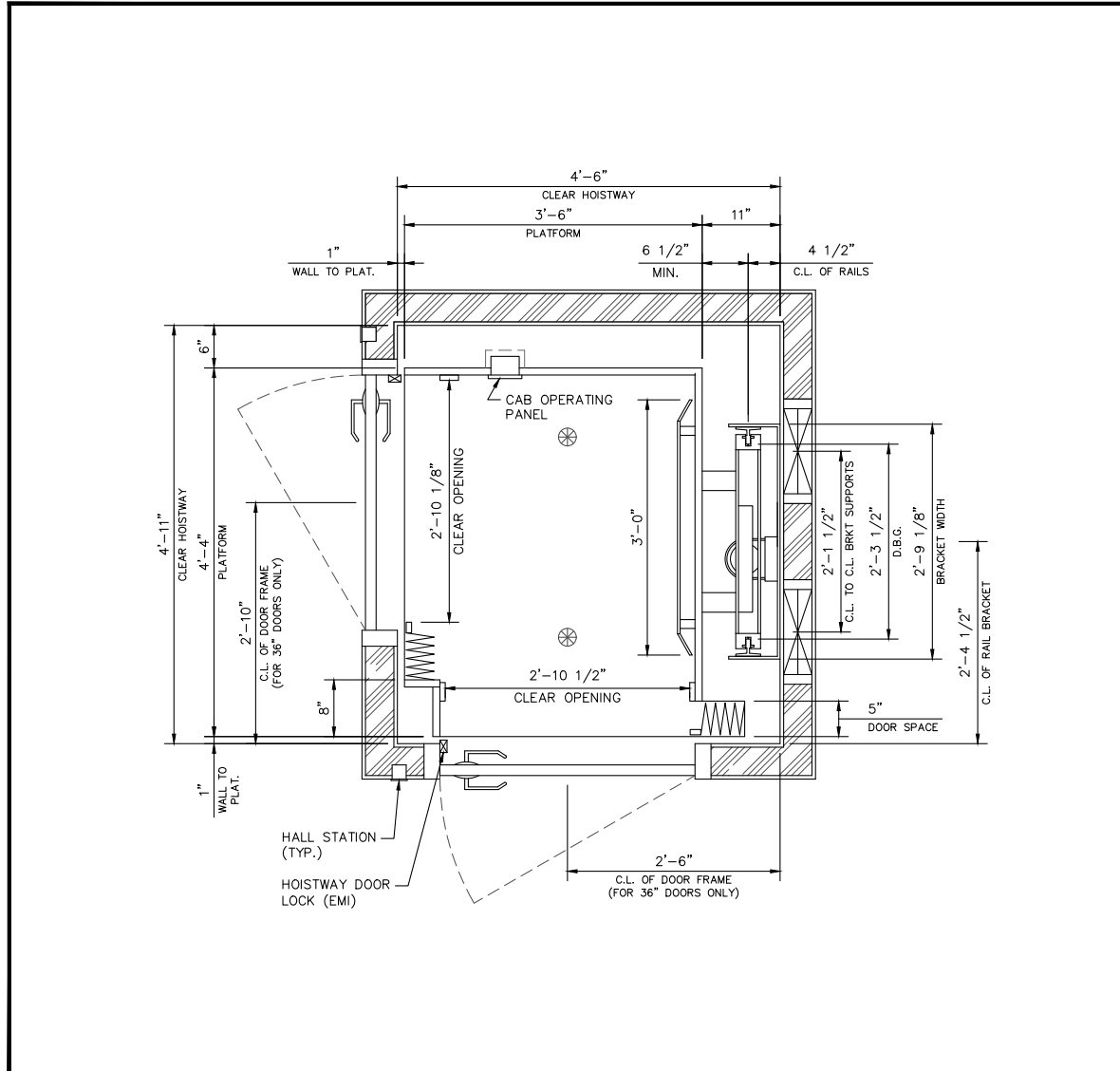

TECHNICAL DATA

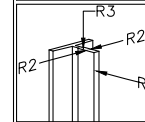

	950 LB. CAP.
R1	105 LB
R2	220 LB
R3	3730 LB

ALL REACTIONS DOUBLED FOR IMPACT HORIZONTAL GUIDE RAIL REACTIONS

DEM 950

NORMAL	JACK LOAD 4275 LB	BUFFER LOAD 4750 LB	CODE YEAR ASME A17.1 2013
--------	----------------------	------------------------	------------------------------

GENERAL INFORMATION		
CAPACITY: 950	SPEED: 40 FPM	STOPS:
OPERATION: SINGLE AUTO	CONTROL: AC MOTOR	OPENINGS:

ELECTRICAL INFORMATION		
POWER: 220 VOLTS AC	1 PHASE	60 HERTZ
HORSE POWER: 3	FLA: 14	RPM: 1725
LIGHT SUPPLY: 110	EMERGENCY BATTERY LIGHTING	

JACK INFORMATION		
PLUNGER DIAMETER:	PLUNGER WALL THICKNESS: .240"	
CYLINDER DIAMETER: 4.5"	CYLINDER WALL THICKNESS: .237"	
TRAVEL:	CLEAR OVERHEAD:	PIT DEPTH:
TOTAL HOISTWAY:	ROPES: (2) 3/8"	PILLAR HEIGHT:
COLLAPSED LENGTH:	STROKE:	JACK WEIGHT:
WORKING PSI:	RELIEF PSI:	GPM:
UP OVERTRAVEL:	DOWN OVERTRAVEL:	

HOISTWAY INFORMATION	
LOCATION OF PILLAR BRKT:	
NUMBER OF BRACKETS:	PISTON EXT.:
BUFFER TYPE: RUBBER PAD	BUFFER STROKE: N/A
OIL LINE: 3/4" SCH 80	OIL REQUIRED: 35 GAL.
GATE TYPE: <input type="checkbox"/> POWERED <input checked="" type="checkbox"/> MANUAL <input checked="" type="checkbox"/> ACCORDION <input type="checkbox"/> SCISSOR	
CAB HEIGHT:	DOOR SIZE:
<input type="checkbox"/> SUBFRAME (2" CLEARANCE)	<input type="checkbox"/> NON-SUBFRAME (1" CLEARANCE)



2210 Allen Dr., Salisbury MD 21801
Phone: (410) 749-3489
Engineering Fax: (410) 749-4503

PROJECT:

AL - 950

REV.	DESCRIPTION	APPROVAL
	PRELIMINARY	

CONTRACT NO.

SHEET 1 OF 3

ADJACENT OPENING AR-950

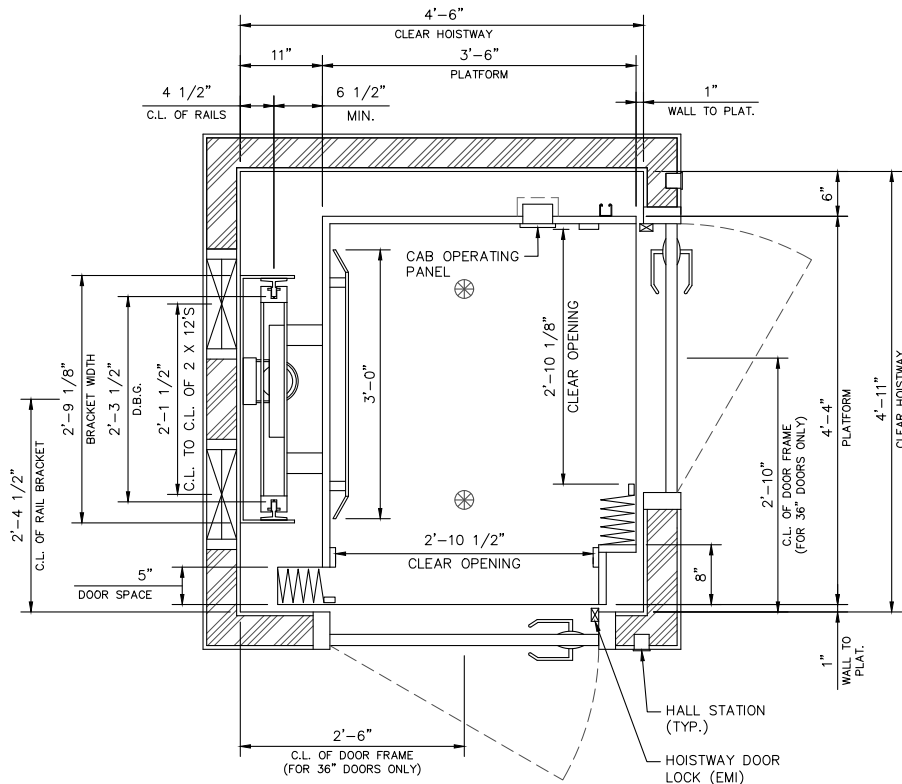

TECHNICAL DATA

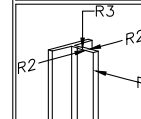

	950 LB. CAP.
R1	105 LB
R2	220 LB
R3	3730 LB

ALL REACTIONS DOUBLED FOR IMPACT HORIZONTAL GUIDE RAIL REACTIONS

DEM 950

NORMAL	JACK LOAD	BUFFER LOAD	CODE YEAR
	4275 LB	4750 LB	ASME A17.1 2013

GENERAL INFORMATION		
CAPACITY: 950	SPEED: 40 FPM	STOPS:
OPERATION: SINGLE AUTO	CONTROL: AC MOTOR	OPENINGS:

ELECTRICAL INFORMATION		
POWER: 220 VOLTS AC	1 PHASE	60 HERTZ
HORSE POWER: 3	FLA: 14	RPM: 1725
LIGHT SUPPLY: 110	EMERGENCY BATTERY LIGHTING	

JACK INFORMATION		
PLUNGER DIAMETER:	PLUNGER WALL THICKNESS: .240"	
CYLINDER DIAMETER: 4.5"	CYLINDER WALL THICKNESS: .237"	
TRAVEL:	CLEAR OVERHEAD:	PIT DEPTH:
TOTAL HOISTWAY:	ROPES: (2) 3/8"	PILLAR HEIGHT:
COLLAPSED LENGTH:	STROKE:	JACK WEIGHT:
WORKING PSI:	RELIEF PSI:	GPM:
UP OVERTRAVEL:	DOWN OVERTRAVEL:	

HOISTWAY INFORMATION		
LOCATION OF PILLAR BRKT:	PISTON EXT.:	
NUMBER OF BRACKETS:	BUFFER TYPE: RUBBER PAD	
BUFFER TYPE: RUBBER PAD	BUFFER STROKE: N/A	
OIL LINE: 3/4" SCH 80	OIL REQUIRED: 35 GAL.	
GATE TYPE: <input type="checkbox"/> POWERED <input checked="" type="checkbox"/> MANUAL <input checked="" type="checkbox"/> ACCORDION <input type="checkbox"/> SCISSOR	CAB HEIGHT:	
<input type="checkbox"/> SUBFRAME (2" CLEARANCE) <input type="checkbox"/> NON-SUBFRAME (1" CLEARANCE)	DOOR SIZE:	

DELAWARE ELEVATOR
est. 1946

2210 Allen Dr., Salisbury MD 21801
Phone: (410) 749-3489
Engineering Fax: (410) 749-4503

PROJECT:

AR - 950

REV.	DESCRIPTION	APPROVAL
	PRELIMINARY	

CONTRACT NO.

SHEET 1 OF 3

IN LINE OPENING IL-950 MAX

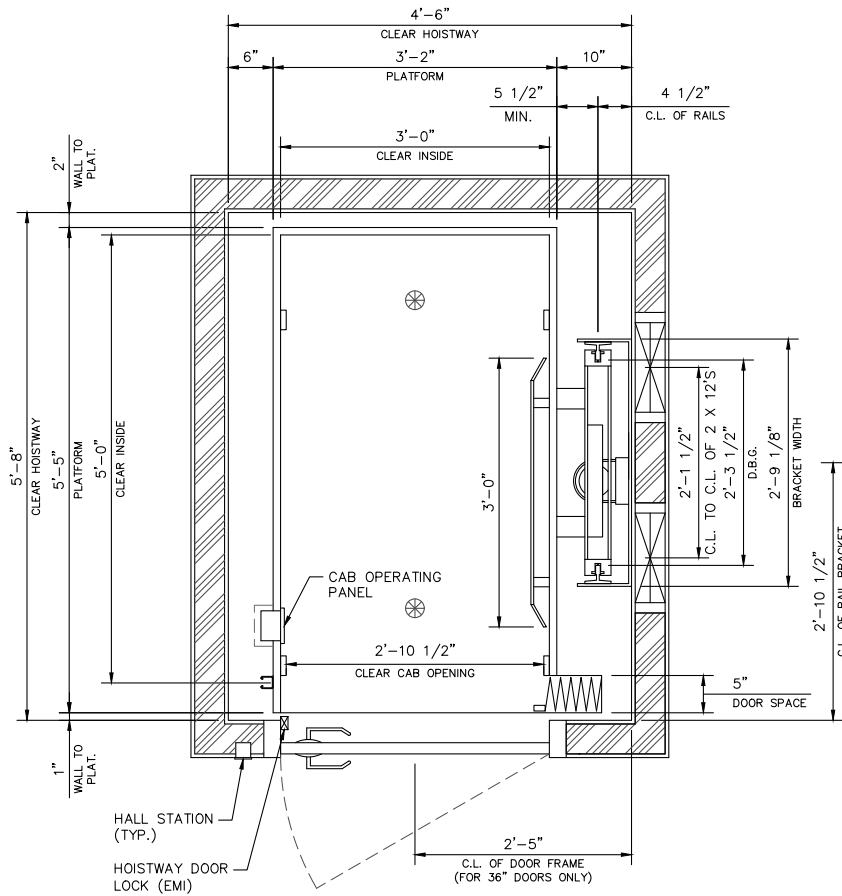

TECHNICAL DATA

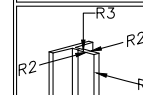

	950 LB. CAP.
R1	105 LB
R2	220 LB
R3	3730 LB

ALL REACTIONS DOUBLED FOR IMPACT HORIZONTAL GUIDE RAIL REACTIONS

DEM 950

NORMAL	JACK LOAD	BUFFER LOAD	CODE YEAR
	4275 LB	4750 LB	ASME A17.1 2013

GENERAL INFORMATION		
CAPACITY: 950	SPEED: 40 FPM	STOPS:
OPERATION: SINGLE AUTO	CONTROL: AC MOTOR	OPENINGS:

ELECTRICAL INFORMATION		
POWER: 220 VOLTS AC	1 PHASE	60 HERTZ
HORSE POWER: 3	FLA: 14	RPM: 1725
LIGHT SUPPLY: 110	EMERGENCY BATTERY LIGHTING	

JACK INFORMATION		
PLUNGER DIAMETER:	PLUNGER WALL THICKNESS: .240"	
CYLINDER DIAMETER: 4.5"	CYLINDER WALL THICKNESS: .237"	
TRAVEL:	CLEAR OVERHEAD:	PIT DEPTH:
TOTAL HOISTWAY:	ROPES: (2) 3/8"	PILLAR HEIGHT:
COLLAPSED LENGTH:	STROKE:	JACK WEIGHT:
WORKING PSI:	RELIEF PSI:	GPM
UP OVERTRAVEL:	DOWN OVERTRAVEL:	

HOISTWAY INFORMATION		
LOCATION OF PILLAR BRKT:	PISTON EXT.:	
NUMBER OF BRACKETS:	BUFFER STROKE: N/A	
BUFFER TYPE: RUBBER PAD	OIL REQUIRED: 35 GAL.	
OIL LINE: 3/4" SCH 80	GATE TYPE: <input type="checkbox"/> POWERED <input checked="" type="checkbox"/> MANUAL <input checked="" type="checkbox"/> ACCORDION <input type="checkbox"/> SCISSOR	
CAB HEIGHT:	DOOR SIZE:	
<input type="checkbox"/> SUBFRAME (2" CLEARANCE)	<input type="checkbox"/> NON-SUBFRAME (1" CLEARANCE)	



2210 Allen Dr., Salisbury MD 21801
 Phone: (410) 749-3489
 Engineering Fax: (410) 749-4503

PROJECT:

IL - 950 MAX

REV.	DESCRIPTION	APPROVAL
	PRELIMINARY	

CONTRACT NO.

SHEET 1 OF 3

IN LINE OPENING IR-950 MAX

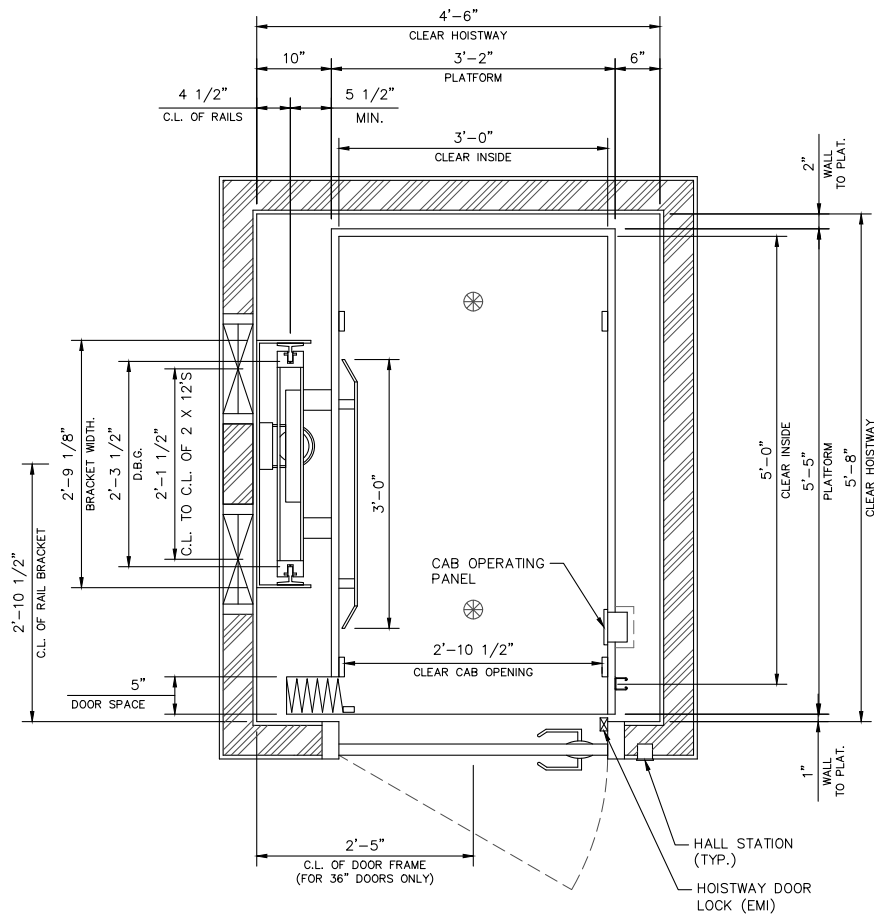

TECHNICAL DATA

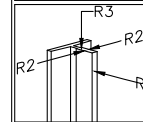

	950 LB. CAP.
R1	105 LB
R2	220 LB
R3	3730 LB

ALL REACTIONS DOUBLED FOR IMPACT HORIZONTAL GUIDE RAIL REACTIONS

DEM 950

NORMAL	JACK LOAD	BUFFER LOAD	CODE YEAR
	4275 LB	4750 LB	ASME A17.1 2013

GENERAL INFORMATION		
CAPACITY: 950	SPEED: 40 FPM	STOPS:
OPERATION: SINGLE AUTO	CONTROL: AC MOTOR	OPENINGS:

ELECTRICAL INFORMATION		
POWER: 220 VOLTS AC	1 PHASE	60 HERTZ
HORSE POWER: 3	FLA: 14	RPM: 1725
LIGHT SUPPLY: 110	EMERGENCY BATTERY LIGHTING	

JACK INFORMATION		
PLUNGER DIAMETER:	PLUNGER WALL THICKNESS: .240"	
CYLINDER DIAMETER: 4.5"	CYLINDER WALL THICKNESS: .237"	
TRAVEL:	CLEAR OVERHEAD:	PIT DEPTH:
TOTAL HOISTWAY:	ROPES: (2) 3/8"	PILLAR HEIGHT:
COLLAPSED LENGTH:	STROKE:	JACK WEIGHT:
WORKING PSI:	RELIEF PSI:	GPM:
UP OVERTRAVEL:	DOWN OVERTRAVEL:	

HOISTWAY INFORMATION	
LOCATION OF PILLAR BRKT:	PISTON EXT.:
NUMBER OF BRACKETS:	BUFFER TYPE: RUBBER PAD
BUFFER STROKE: N/A	OIL LINE: 3/4" SCH 80
OIL REQUIRED: 35 GAL.	GATE TYPE: <input type="checkbox"/> POWERED <input checked="" type="checkbox"/> MANUAL <input checked="" type="checkbox"/> ACCORDION <input type="checkbox"/> SCISSOR
CAB HEIGHT:	DOOR SIZE:
<input type="checkbox"/> SUBFRAME (2" CLEARANCE)	<input type="checkbox"/> NON-SUBFRAME (1" CLEARANCE)



2210 Allen Dr., Salisbury MD 21801
Phone: (410) 749-3489
Engineering Fax: (410) 749-4503

PROJECT:

IR - 950 MAX

REV.	DESCRIPTION	APPROVAL
	PRELIMINARY	

CONTRACT NO.

SHEET 1 OF 3

IN LINE OPENING XL-950 MAX

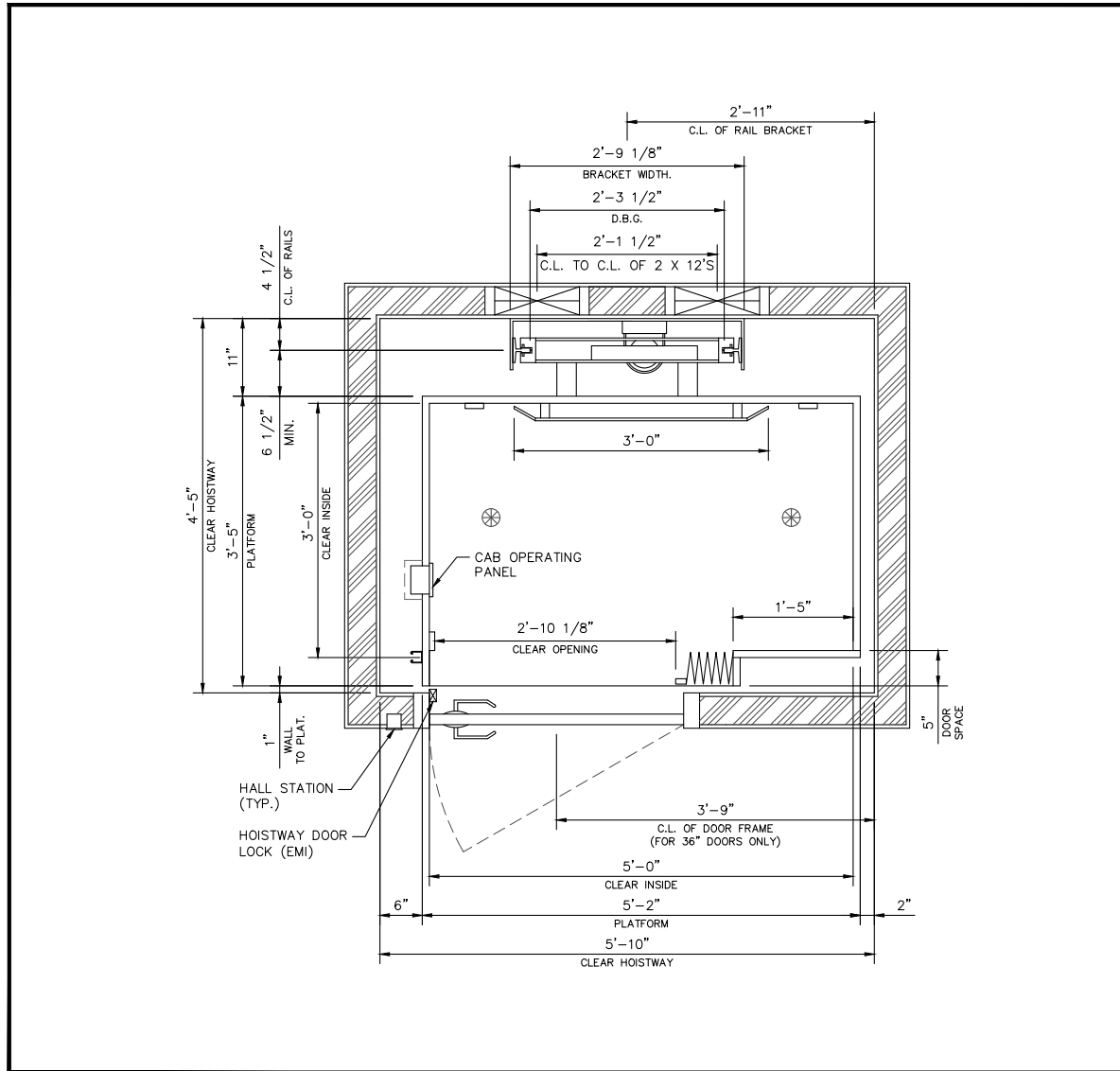

TECHNICAL DATA

	950 LB. CAP.	
R1	105 LB	ALL REACTIONS DOUBLED FOR IMPACT HORIZONTAL GUIDE RAIL REACTIONS
R2	220 LB	
R3	3730 LB	

DEM 950			
NORMAL	JACK LOAD 4275 LB	BUFFER LOAD 4750 LB	CODE YEAR ASME A17.1 2013

GENERAL INFORMATION		
CAPACITY: 950	SPEED: 40 FPM	STOPS:
OPERATION: SINGLE AUTO	CONTROL: AC MOTOR	OPENINGS:

ELECTRICAL INFORMATION		
POWER: 220 VOLTS AC	1 PHASE	60 HERTZ
HORSE POWER: 3	FLA: 14	RPM: 1725
LIGHT SUPPLY: 110	EMERGENCY BATTERY LIGHTING	

JACK INFORMATION		
PLUNGER DIAMETER:	PLUNGER WALL THICKNESS: .240"	
CYLINDER DIAMETER: 4.5"	CYLINDER WALL THICKNESS: .237"	
TRAVEL:	CLEAR OVERHEAD:	PIT DEPTH:
TOTAL HOISTWAY:	ROPES: (2) 3/8"	PILLAR HEIGHT:
COLLAPSED LENGTH:	STROKE:	JACK WEIGHT:
WORKING PSI:	RELIEF PSI:	GPM
UP OVERTRAVEL:	DOWN OVERTRAVEL:	

HOISTWAY INFORMATION	
LOCATION OF PILLAR BRKT:	PISTON EXT.:
NUMBER OF BRACKETS:	BUFFER STROKE: N/A
BUFFER TYPE: RUBBER PAD	OIL REQUIRED: 35 GAL.
OIL LINE: 3/4" SCH 80	GATE TYPE: <input type="checkbox"/> POWERED <input checked="" type="checkbox"/> MANUAL <input checked="" type="checkbox"/> ACCORDION <input type="checkbox"/> SCISSOR
CAB HEIGHT:	DOOR SIZE:
<input type="checkbox"/> SUBFRAME (2" CLEARANCE)	<input type="checkbox"/> NON-SUBFRAME (1" CLEARANCE)



2210 Allen Dr., Salisbury MD 21801
 Phone: (410) 749-3489
 Engineering Fax: (410) 749-4503

PROJECT: **XL - 950 MAX**

REV.	DESCRIPTION	APPROVAL
	PRELIMINARY	

CONTRACT NO. _____ SHEET 1 OF 3

IN LINE OPENING XR-950 MAX

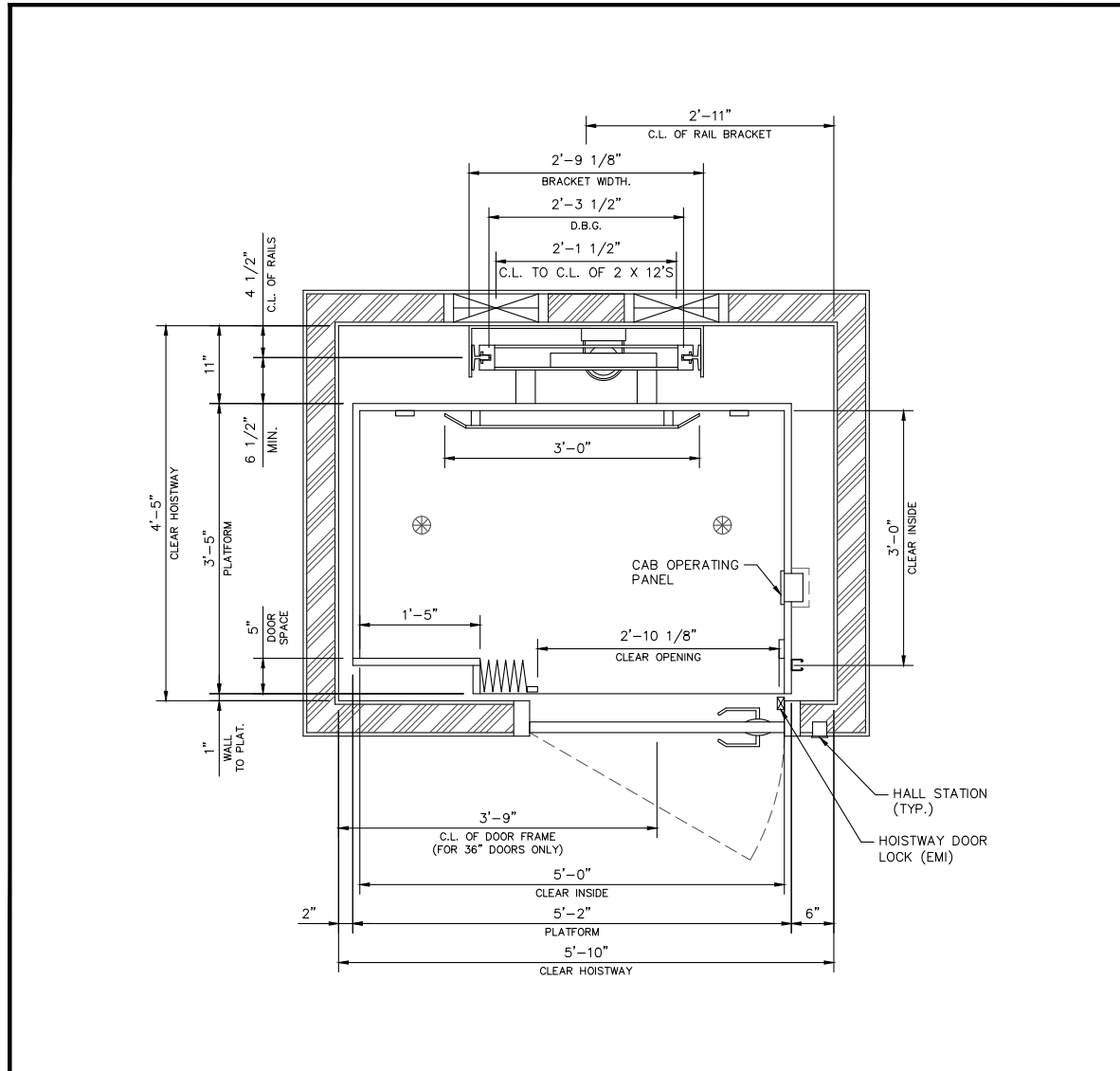

TECHNICAL DATA

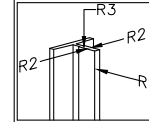

	950 LB. CAP.
R1	105 LB
R2	220 LB
R3	3730 LB

ALL REACTIONS DOUBLED FOR IMPACT HORIZONTAL GUIDE RAIL REACTIONS

DEM 950

NORMAL	JACK LOAD	4275 LB	BUFFER LOAD	4750 LB	CODE YEAR	ASME A17.1 2013
	GENERAL INFORMATION					

CAPACITY: 950	SPEED: 40 FPM	STOPS:
OPERATION: SINGLE AUTO	CONTROL: AC MOTOR	OPENINGS:

ELECTRICAL INFORMATION		
POWER: 220 VOLTS AC	1 PHASE	60 HERTZ
HORSE POWER: 3	FLA: 14	RPM: 1725
LIGHT SUPPLY: 110	EMERGENCY BATTERY LIGHTING	

JACK INFORMATION		
PLUNGER DIAMETER:	PLUNGER WALL THICKNESS: .240"	
CYLINDER DIAMETER: 4.5"	CYLINDER WALL THICKNESS: .237"	
TRAVEL:	CLEAR OVERHEAD:	PIT DEPTH:
TOTAL HOISTWAY:	ROPES: (2) 3/8"	PILLAR HEIGHT:
COLLAPSED LENGTH:	STROKE:	JACK WEIGHT:
WORKING PSI:	RELIEF PSI:	GPM
UP OVERTRAVEL:	DOWN OVERTRAVEL:	

HOISTWAY INFORMATION		
LOCATION OF PILLAR BRKT:	PISTON EXT.:	
NUMBER OF BRACKETS:	BUFFER STROKE: N/A	
BUFFER TYPE: RUBBER PAD	OIL LINE: 3/4" SCH 80	
OIL LINE: 3/4" SCH 80	OIL REQUIRED: 35 GAL.	
GATE TYPE: <input type="checkbox"/> POWERED <input checked="" type="checkbox"/> MANUAL <input checked="" type="checkbox"/> ACCORDION <input type="checkbox"/> SCISSOR	CAB HEIGHT:	
<input type="checkbox"/> SUBFRAME (2" CLEARANCE) <input type="checkbox"/> NON-SUBFRAME (1" CLEARANCE)	DOOR SIZE:	



2210 Allen Dr., Salisbury MD 21801
Phone: (410) 749-3489
Engineering Fax: (410) 749-4503

PROJECT:

XR - 950 MAX

REV.	DESCRIPTION	APPROVAL
	PRELIMINARY	

CONTRACT NO.

SHEET 1 OF 3

FRONT & REAR FRL-950 MAX

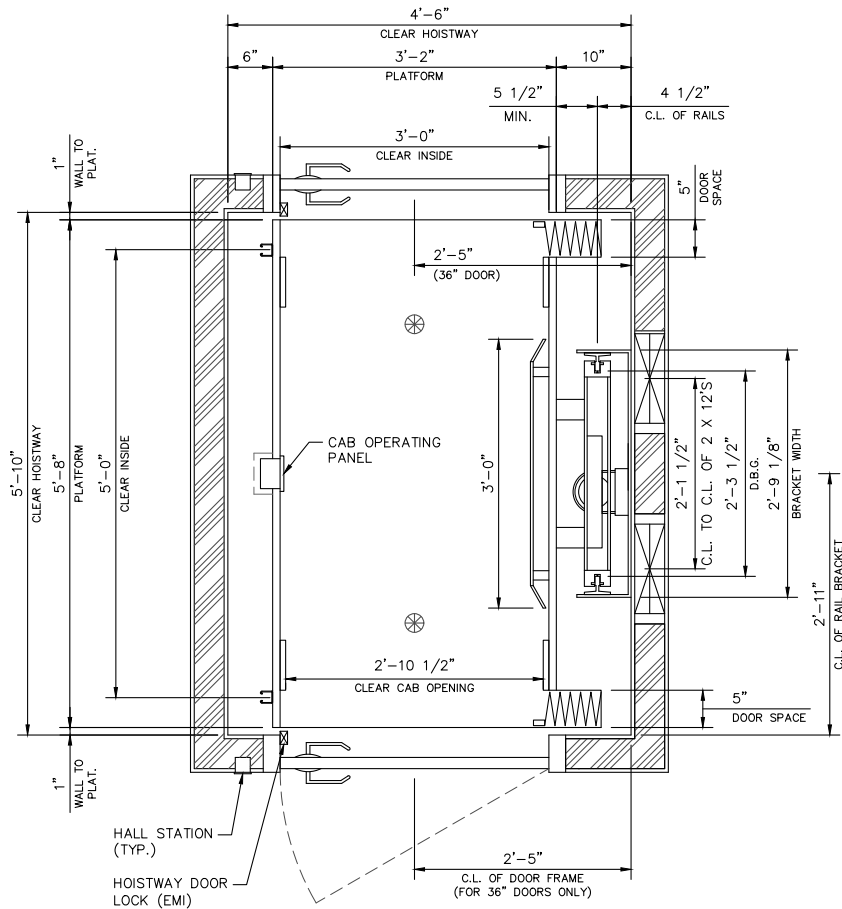

TECHNICAL DATA

		950 LB. CAP.	ALL REACTIONS DOUBLED FOR IMPACT HORIZONTAL GUIDE RAIL REACTIONS
	R1	105 LB	
	R2	220 LB	
	R3	3730 LB	

DEM 950			
NORMAL	JACK LOAD	BUFFER LOAD	CODE YEAR
	4275 LB	4750 LB	ASME A17.1 2013

GENERAL INFORMATION		
CAPACITY: 950	SPEED: 40 FPM	STOPS:
OPERATION: SINGLE AUTO	CONTROL: AC MOTOR	OPENINGS:

ELECTRICAL INFORMATION		
POWER: 220 VOLTS AC	1 PHASE	60 HERTZ
HORSE POWER: 3	FLA: 14	RPM: 1725
LIGHT SUPPLY: 110	EMERGENCY BATTERY LIGHTING	

JACK INFORMATION		
PLUNGER DIAMETER:	PLUNGER WALL THICKNESS: .240"	
CYLINDER DIAMETER: 4.5"	CYLINDER WALL THICKNESS: .237"	
TRAVEL:	CLEAR OVERHEAD:	PIT DEPTH:
TOTAL HOISTWAY:	ROPES: (2) 3/8"	PILLAR HEIGHT:
COLLAPSED LENGTH:	STROKE:	JACK WEIGHT:
WORKING PSI:	RELIEF PSI:	GPM
UP OVERTRAVEL:	DOWN OVERTRAVEL:	

HOISTWAY INFORMATION	
LOCATION OF PILLAR BRKT:	PISTON EXT.:
NUMBER OF BRACKETS:	BUFFER STROKE: N/A
BUFFER TYPE: RUBBER PAD	OIL REQUIRED: 35 GAL.
OIL LINE: 3/4" SCH 80	GATE TYPE: <input type="checkbox"/> POWERED <input checked="" type="checkbox"/> MANUAL <input checked="" type="checkbox"/> ACCORDION <input type="checkbox"/> SCISSOR
CAB HEIGHT:	DOOR SIZE:
<input type="checkbox"/> SUBFRAME (2" CLEARANCE)	<input type="checkbox"/> NON-SUBFRAME (1" CLEARANCE)



2210 Allen Dr., Salisbury MD 21801
 Phone: (410) 749-3489
 Engineering Fax: (410) 749-4503

PROJECT: **FRL - 950 MAX**

REV.	DESCRIPTION	APPROVAL
	PRELIMINARY	

CONTRACT NO. SHEET 1 OF 3

FRONT & REAR FRR-950 MAX

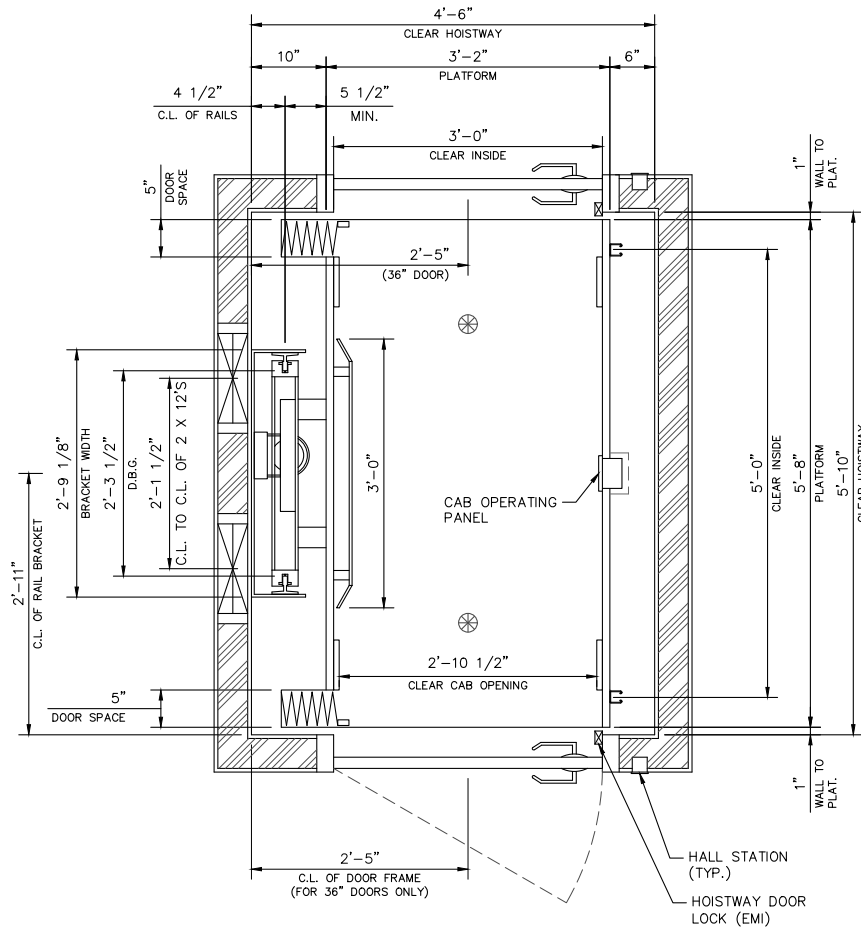

TECHNICAL DATA

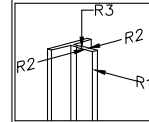

	950 LB. CAP.
R1	105 LB
R2	220 LB
R3	3730 LB

ALL REACTIONS DOUBLED
FOR IMPACT
HORIZONTAL GUIDE RAIL
REACTIONS

DEM 950

NORMAL	JACK LOAD	BUFFER LOAD	CODE YEAR
	4275 LB	4750 LB	ASME A17.1 2013

GENERAL INFORMATION		
CAPACITY: 950	SPEED: 40 FPM	STOPS:
OPERATION: SINGLE AUTO	CONTROL: AC MOTOR	OPENINGS:

ELECTRICAL INFORMATION		
POWER: 220 VOLTS AC	1 PHASE	60 HERTZ
HORSE POWER: 3	FLA: 14	RPM: 1725
LIGHT SUPPLY: 110		EMERGENCY BATTERY LIGHTING

JACK INFORMATION		
PLUNGER DIAMETER:	PLUNGER WALL THICKNESS: .240"	
CYLINDER DIAMETER: 4.5"	CYLINDER WALL THICKNESS: .237"	
TRAVEL:	CLEAR OVERHEAD:	PIT DEPTH:
TOTAL HOISTWAY:	ROPES: (2) 3/8"	PILLAR HEIGHT:
COLLAPSED LENGTH:	STROKE:	JACK WEIGHT:
WORKING PSI:	RELIEF PSI:	GPM
UP OVERTRAVEL:	DOWN OVERTRAVEL:	

HOISTWAY INFORMATION	
LOCATION OF PILLAR BRKT:	
NUMBER OF BRACKETS:	PISTON EXT.:
BUFFER TYPE: RUBBER PAD	BUFFER STROKE: N/A
OIL LINE: 3/4" SCH 80	OIL REQUIRED: 35 GAL.
GATE TYPE: <input type="checkbox"/> POWERED <input checked="" type="checkbox"/> MANUAL <input checked="" type="checkbox"/> ACCORDION <input type="checkbox"/> SCISSOR	
CAB HEIGHT:	DOOR SIZE:
<input type="checkbox"/> SUBFRAME (2" CLEARANCE)	<input type="checkbox"/> NON-SUBFRAME (1" CLEARANCE)

**DELAWARE
ELEVATOR**
est. 1946

2210 Allen Dr., Salisbury MD 21801
Phone: (410) 749-3489
Engineering Fax: (410) 749-4503

PROJECT:

FRR - 950 MAX

REV.	DESCRIPTION	APPROVAL
	PRELIMINARY	

CONTRACT NO.

SHEET 1 OF 3

ADJACENT OPENING AL-950 MAX

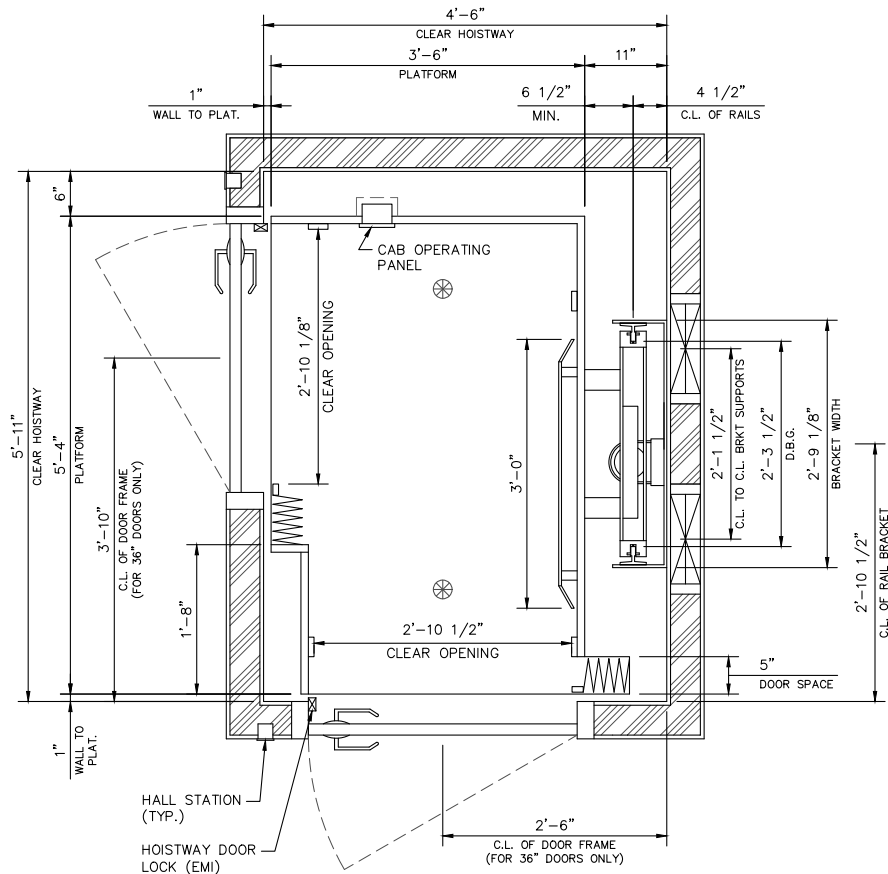

TECHNICAL DATA

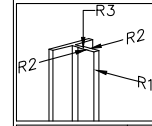

	950 LB. CAP.
R1	105 LB
R2	220 LB
R3	3730 LB

ALL REACTIONS DOUBLED FOR IMPACT HORIZONTAL GUIDE RAIL REACTIONS

DEM 950

NORMAL	JACK LOAD	BUFFER LOAD	CODE YEAR
	4275 LB	4750 LB	ASME A17.1 2013

GENERAL INFORMATION		
CAPACITY: 950	SPEED: 40 FPM	STOPS:
OPERATION: SINGLE AUTO	CONTROL: AC MOTOR	OPENINGS:

ELECTRICAL INFORMATION		
POWER: 220 VOLTS AC	1 PHASE	60 HERTZ
HORSE POWER: 3	FLA: 14	RPM: 1725
LIGHT SUPPLY: 110	EMERGENCY BATTERY LIGHTING	

JACK INFORMATION		
PLUNGER DIAMETER:	PLUNGER WALL THICKNESS: .240"	
CYLINDER DIAMETER: 4.5"	CYLINDER WALL THICKNESS: .237"	
TRAVEL:	CLEAR OVERHEAD:	PIT DEPTH:
TOTAL HOISTWAY:	ROPES: (2) 3/8"	PILLAR HEIGHT:
COLLAPSED LENGTH:	STROKE:	JACK WEIGHT:
WORKING PSI:	RELIEF PSI:	GPM
UP OVERTRAVEL:	DOWN OVERTRAVEL:	

HOISTWAY INFORMATION	
LOCATION OF PILLAR BRKT:	PISTON EXT.:
NUMBER OF BRACKETS:	BUFFER STROKE: N/A
BUFFER TYPE: RUBBER PAD	OIL REQUIRED: 35 GAL.
OIL LINE: 3/4" SCH 80	GATE TYPE: <input type="checkbox"/> POWERED <input checked="" type="checkbox"/> MANUAL <input checked="" type="checkbox"/> ACCORDION <input type="checkbox"/> SCISSOR
CAB HEIGHT:	DOOR SIZE:
<input type="checkbox"/> SUBFRAME (2" CLEARANCE)	<input type="checkbox"/> NON-SUBFRAME (1" CLEARANCE)



2210 Allen Dr., Salisbury MD 21801
Phone: (410) 749-3489
Engineering Fax: (410) 749-4503

PROJECT:

AL - 950 MAX

REV.	DESCRIPTION	APPROVAL
	PRELIMINARY	

CONTRACT NO.

SHEET 1 OF 3

ADJACENT OPENING AR-950 MAX

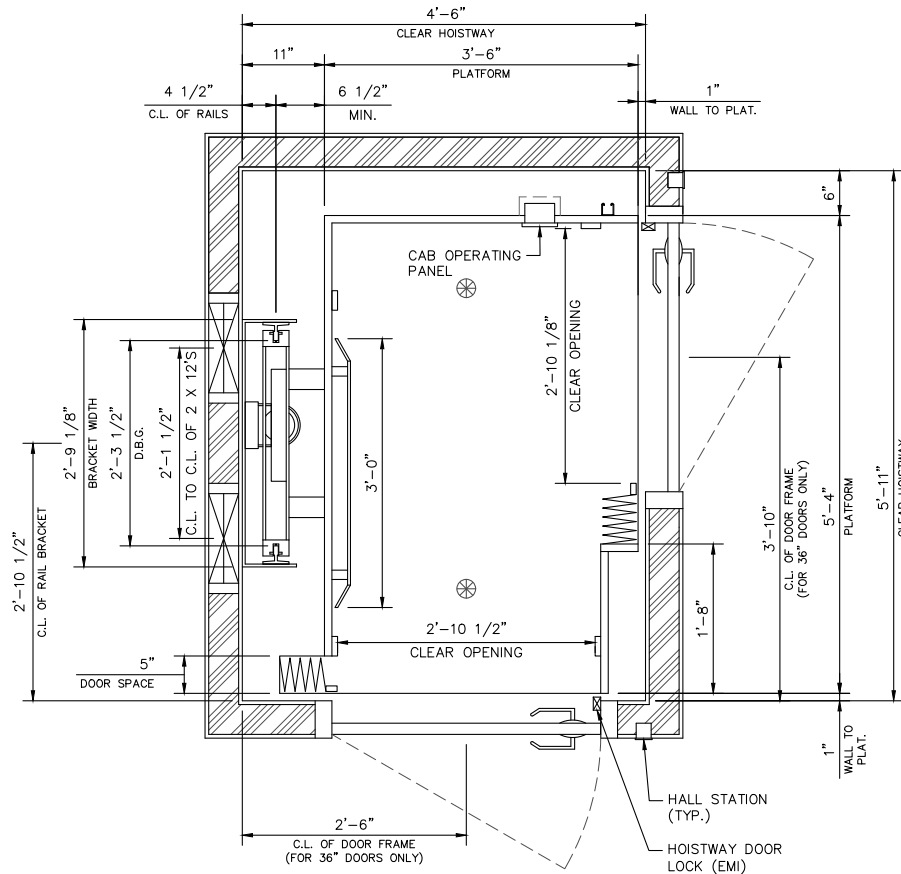

TECHNICAL DATA

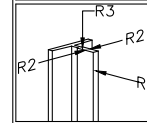

	950 LB. CAP.
R1	105 LB
R2	220 LB
R3	3730 LB

ALL REACTIONS DOUBLED FOR IMPACT
HORIZONTAL GUIDE RAIL REACTIONS

DEM 950

NORMAL	JACK LOAD 4275 LB	BUFFER LOAD 4750 LB	CODE YEAR ASME A17.1 2013
--------	----------------------	------------------------	------------------------------

GENERAL INFORMATION		
CAPACITY: 950	SPEED: 40 FPM	STOPS:
OPERATION: SINGLE AUTO	CONTROL: AC MOTOR	OPENINGS:

ELECTRICAL INFORMATION		
POWER: 220 VOLTS AC	1 PHASE	60 HERTZ
HORSE POWER: 3	FLA: 14	RPM: 1725
LIGHT SUPPLY: 110	EMERGENCY BATTERY LIGHTING	

JACK INFORMATION		
PLUNGER DIAMETER:	PLUNGER WALL THICKNESS: .240"	
CYLINDER DIAMETER: 4.5"	CYLINDER WALL THICKNESS: .237"	
TRAVEL:	CLEAR OVERHEAD:	PIT DEPTH:
TOTAL HOISTWAY:	ROPES: (2) 3/8"	PILLAR HEIGHT:
COLLAPSED LENGTH:	STROKE:	JACK WEIGHT:
WORKING PSI:	RELIEF PSI:	GPM:
UP OVERTRAVEL:	DOWN OVERTRAVEL:	

HOISTWAY INFORMATION	
LOCATION OF PILLAR BRKT:	
NUMBER OF BRACKETS:	PISTON EXT.:
BUFFER TYPE: RUBBER PAD	BUFFER STROKE: N/A
OIL LINE: 3/4" SCH 80	OIL REQUIRED: 35 GAL.
GATE TYPE: <input type="checkbox"/> POWERED <input checked="" type="checkbox"/> MANUAL <input checked="" type="checkbox"/> ACCORDION <input type="checkbox"/> SCISSOR	
CAB HEIGHT:	DOOR SIZE:
<input type="checkbox"/> SUBFRAME (2" CLEARANCE)	<input type="checkbox"/> NON-SUBFRAME (1" CLEARANCE)



2210 Allen Dr., Salisbury MD 21801
Phone: (410) 749-3489
Engineering Fax: (410) 749-4503

PROJECT:

AR - 950 MAX

REV.	DESCRIPTION	APPROVAL
	PRELIMINARY	
CONTRACT NO.		SHEET 1 OF 3

NOTES

HOME ELEVATOR 3/4" X 4"

Delaware Elevator Corporation installs a fully code compliant elevator per the ASME ANSI A17.1 National Safety Code for Elevators - Section 5.3 Private Residences Elevators, Rule 5.3.1.4.2. of the elevator safety code states that the provided hoistway must meet the below clearance requirements within a private residence state:

- The clearance between the hoistway face of the hoistway doors and the hoistway edge of the landing sill shall not exceed 3/4" (0.75 in).
- The distance between the hoistway face of the landing door and the car door or gate shall not exceed 4" (inches).

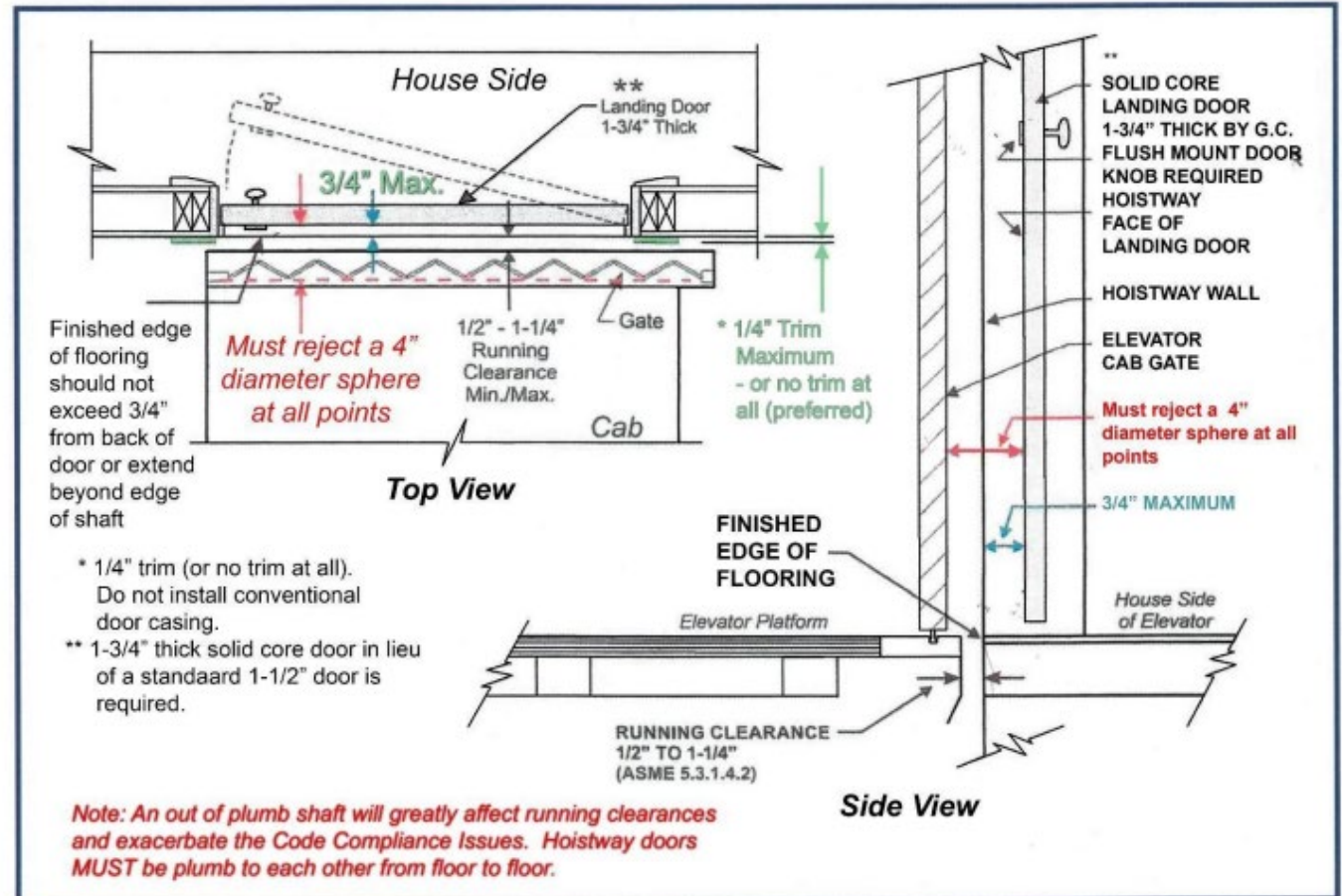

THANK YOU!

To our customers for giving Delaware Elevator the opportunity to give back to our community



At Delaware Elevator we have built lasting relationships with exceptional partners.





OFFICE LOCATIONS

Delaware Elevator Headquarters

Phone: 800-787-0436
2210 Allen Drive
Salisbury, MD 21801
P.O. Box 412
Salisbury, MD 21803

Delaware Elevator Florida Headquarters

1001 NW Broken Sound Pkwy, Suite C
Boca Raton, FL 33487

Manufacturing Office

27685 Rockawalkin Ridge Rd
Salisbury, MD 21801

Ocean City Office

7006 Unit A, Coastal Hwy.
Ocean City, MD 21842

DC/Metro Office

9010 Maier Road Suite 100
Laurel, MD 20723

VA Beach Office

361 Cleveland Place
Suite 104
Virginia Beach, VA

Wilmington Office

2907 Ogletown Road
Newark, DE 19713

Delaware Elevator Mexico

Local #105
Royal Pacific Yacht Club
Paseo de la Marina
Marina Vallarta
Puerto Vallarta, Jalisco, Mexico 48335
Phone: 322-192-8041

Minnesota Office

360 Pierce Ave. Ste. 207
N. Mankato, MN 56003

Florida Keys Office

89015 Overseas Highway, Unit #1
Tavernier, FL 33070

North Florida Office

2550 N. State St, Unit #3
Bunnell, FL 32110

Jacksonville Florida Office

13720 Old St. Augustine Rd.
Suite 8-227
Jacksonville, FL 32258

Central Florida Office

1304 Gary Road
Lakeland, FL 33801

Carolinas Office

2024 Independence Commerce Dr.,
Unit A
Matthews, NC 28105

DELAWAREELEVATOR.COM

2210 Allen Drive, Salisbury, MD 21801